

## Endurance Test

WHEN the International Geophysical Year began last month an SWI (Special World Interval) was already in force and observers in all parts of the world were hard at work measuring the effects of large solar flares on the ionosphere, the earth's magnetic field, the aurorae and many other phenomena. The sun had collaborated in confirming the choice of timing of the experiment, the world telecommunication network (tested by practice alerts since January) went "operational" for the first time, and all the months of elaborate preparation for this massive international scientific experiment gave place to the second phase, namely that of observation.

Much of the information we have about the constitution of the ionosphere is obtained by radio pulse reflection at vertical incidence. The number of stations making this type of continuous automatic measurement has been trebled and particular attention is being paid to the regions near the earth's geomagnetic equator. The basic information given by radio sounding methods is the time taken for the pulse to go and return through a heterogeneous stratified dielectric, and although much has been deduced from studies of the behaviour of pulses of different frequency, the direct physical measurement of electron density and dielectric constant has only recently been extended by rockets above the 20-mile limit of balloons. During the IGY there is to be a much-increased expenditure of rockets, including at least twelve rounds of the specially designed "Skylark" from the Woomera range.

Studies of the turbulence of the upper atmosphere and the measurement of drifts in the ionosphere, hitherto made from observations of the scintillation of noise from radio "stars," will, if all goes well, be given an element of greater precision when the fixed-frequency, point-source transmitters of the artificial satellites come into operation. Those stations which are fortunate enough to be able to plot the track of the satellites visually, as well as by radio methods, will have a double check on the refracting properties of the ionosphere. It is confidently expected that signals will be heard in this country from the

American satellite, though its power will be only of the order of milliwatts, and plans have been made to follow its course with the Jodrell Bank telescope and by means of a special interferometer to be set up and operated by the Royal Aircraft Establishment at Lasham aerodrome in Hampshire. At this distance and with a low-elevation propagation path through the atmosphere the apparent track of the satellite will show measurable deviations from its true velocity. From these deviations it is hoped to learn something more of irregularities of the ionosphere and their variation with height.

Which turns our attention to the third and most important phase—the reduction and digestion of results. This will not begin in earnest until the end of IGY in 1958, when copies of all the figures will be sent to the World Data Centres in the U.S.A., U.S.S.R. and elsewhere.

The IGY already stands as a monument to Man's ability to organize on an international scale, and will require of him qualities of steadfastness and concentration in making what will often be dull routine observations. In this country, Sir David Brunt, Secretary of the Royal Society, has been intimately concerned with the detailed preparation of the British contribution, including responsibility for the establishment of the Halley Bay observatory in the Antarctic, and we can wholeheartedly endorse his hope, expressed at a recent conference, that we shall be given the wit and perseverance, when the time comes, to make good use of the results of all this collective effort. Some lines of enquiry are already laid down with reasonable precision and have as their object the filling in of blank areas of world maps of known geophysical phenomena by the addition of data from strategically placed new observing stations. Others, deriving from the use of new tools for measurement, such as the rocket and the artificial satellite, will extend the range of measurement and confirm or refute those of our ideas which at present rest only on hypothesis. But the hidden treasure of new knowledge can be revealed only by painstaking sifting and imaginative correlation of apparently unrelated data.

# Colour Television Marks Time

RESEARCH TRENDS FROM THE PARIS INTERNATIONAL SYMPOSIUM

**A**PART from a new French colour system which may prove a competitor to the N.T.S.C. system on 819 lines, *Wireless World* did not find anything at the Paris Symposium to indicate a turn in the tide away from the broad principles and techniques of American colour television. It is true that development is going ahead on a simple and cheap receiver display device to make colour television an economic possibility for the ordinary viewer. And if, as seems possible, this turns out to be something like the single-gun beam-switching or -indexing tubes, it may recommend a transmission system somewhat different from the American pattern. But no hint of this came out in Paris. Rather we found that most of the papers described researches which either lent direct support to the N.T.S.C. system or were neutral on this point.

It was perhaps significant that the French company Laboratoires d'Electronique et de Physique Appliquées, which described and demonstrated its own "double-message" system, also described and demonstrated 819-line and 625-line versions of the N.T.S.C. system. (Under the particular viewing conditions and with the display equipment available it was difficult to see much difference between any of them.) Moreover, it appears that the powerful Philips organization in Holland, which has devised its own "two-subcarrier" system, is now virtually won over to the N.T.S.C. system. In a paper describing their experiments with a 625-line version, they stated the definite opinion that such a system would be the best one for introduction in Europe.

## Bandwidth Requirements

A question which seemed to concern a great many contributors to the Symposium was the bandwidth of colour television signals—particularly with regard to the subjective requirements of the viewer in picture sharpness and clarity. Here the general view seemed to be that the bandwidth of the luminance, or brightness, signal could be considerably smaller than that generally laid down for existing monochrome transmissions. For example, a paper from the Sylvania-Thorn company (Britain) described subjective viewing tests which found the optimum bandwidth for 405-line monochrome pictures, viewed at ten times the picture height, to be only 1.5 Mc/s (and for 625-line pictures only 3.0 Mc/s). In colour pictures a B.B.C. communication stated that if the chrominance component is given our full 3-Mc/s bandwidth, then the luminance component can be somewhat degraded before any loss of sharpness becomes visible. An R.C.A. paper mentioned that some statistical redundancy in American television pictures can be removed simply by passing the video signal through a 2-Mc/s low-pass filter and the result is still very acceptable. All this was confirmed, said a representative of one British receiver manufacturer, by the fact that the

buying public do not seem to show any preference for commercial receivers with wider bandwidths.

The point here seems to be that in the N.T.S.C. system there is really no need for the colour sub-carrier signal to share the same band as the brightness (monochrome) signal because the viewer's eye is unable to perceive the brightness information over the shared part of the video spectrum. In other words the brightness signal could be band-limited at the optimum point so that the two signals would not overlap and there would be no sub-carrier interference problem. It is well known, of course, that American monochrome receivers do in fact achieve this effect when displaying compatible N.T.S.C. pictures by virtue of their somewhat restricted video bandwidths.

## High Definition Pictures

The idea was illustrated in another way by the demonstration of the French 819-line N.T.S.C. system, with its exceptionally wide 10-Mc/s monochrome bandwidth. Glancing at the compatible picture on a black-and-white receiver, one was almost impelled by the extreme fineness of detail to view it at close quarters—much closer than ten times the picture height—but then the disadvantage of the wide bandwidth became immediately apparent in the marked visibility of the colour sub-carrier dot pattern.

Incidentally, it was perhaps significant to hear two representatives of British television broadcasting privately, enthusing over the French 819-line monochrome pictures, which at their best are undoubtedly superior to the best we can do on 405 lines and 3-Mc/s bandwidth. On the other hand, it was observed that the higher definition does not seem to offer much advantage in colour television—particularly when the R.C.A. tri-colour tube with its restricted resolution of 400 lines is used as a display device.

Indeed it is true to say that most of the existing colour display devices leave much to be desired in general performance, quite apart from the question of cost. A comparative paper from Hazeltine in the U.S.A. put the single-gun beam-switching and beam-indexing tubes first in order of performance, followed by the three-gun focus-grid tube, the three-gun shadow-mask tube and finally the three-tube projection system. This was also roughly the order of increasing cost. A representative of Pye, however, disagreed with the low performance assessment of projection systems. Describing a large-screen projection equipment using three Schmidt-type optical systems, he mentioned that the problem of accurate registration had been largely overcome by making all adjustments mechanical in form so that any drifts resulting from electrical controls were eliminated. This equipment used large dichroic mirrors for optical superimposition, but another speaker said he had used side-by-side Schmidt systems successfully (with

optical correction) and thereby gained in light output, definition and contrast ratio.

Another problem in registration, but this time in direct-viewing colour c.r. tubes, is to get the electron beam to fall accurately on the required phosphor at all points without energizing adjacent colours. An improved tube described in a Philips paper gave a "post focusing" action between a mask (comparable with a shadow mask) and the screen. The focusing was obtained by slits in the mask of almost elliptical shape and a reducing voltage gradient between the mask and screen. Because the holes in the focusing mask were larger than in the R.C.A. shadow mask, a considerable improvement in transparency was obtained (actually a transparency of 60 per cent), but since the screen potential was reduced by a factor of 4 there was not an equivalent gain in brightness. However, further improvements were being made by the introduction of a second mask.

A difficulty comparable with registration is the accurate matching of the gamma characteristic in the three electron guns of a tri-colour c.r. tube or in three separate projection tubes. Discrepancies can cause errors, particularly in the reproduction of brightness information. A subjective viewing test described in a Mullard paper was designed to discover what differences were permissible between the transfer characteristics of the three primary-colour channels of a colour system, and this led to the conclusion that the tolerances on tube manufacture would be very tight indeed.

At the transmitting end, there are equivalent difficulties in the registration and matching of the three camera pick-up tubes, and any discrepancies are particularly noticeable in the quality of the composite black-and-white picture. A paper from Telefunken (Germany) emphasized the desirability of using just a single tube with a three-colour filter to avoid this situation but here of course the optical and instrumental difficulties are enormous. The photoconductive pick-up tube was said to have great possibilities for three-colour cameras, and a new type using a layer of lead monoxide for the light-sensitive element was described in another Philips paper. This tube was characterized by its high sensitivity, fast response at low light levels and negligible dark current. The usual problem of storage in photoconductive tubes was overcome because the decay of the signal after interruption of light was primarily determined by the discharging scanning beam and not by the inherent inertia of the photoconductor itself.

### Receiver Performance

It was disappointing to hear no results of the B.B.C. experimental transmissions on the N.T.S.C. system, but one British receiver manufacturer (G.E.C.) described subjective viewing tests which took advantage of these transmissions to discover permissible tolerances in colour receiver performance. In particular the phase stability of the local colour reference oscillator is important because it controls the hue of the displayed colours. Deliberate phase changes were made gradually to simulate drift and it appeared that the more discriminating viewers would not tolerate more than a  $\pm 5^\circ$  variation in phase angle. At the same time, there was a range of adjustment as wide as  $30^\circ$  over which they were willing to actually set the reference phase control

for optimum colour reproduction. Viewers' ideas of what constituted pure white on the screen were somewhat varied, and changed with the room lighting. The results, moreover, were not centred round the official Illuminant "C" on the C.I.E. chromaticity diagram.

The G.E.C. contributors had also investigated the subjective effects of noise in colour television receivers. Another kind of interference, resulting from multi-path reception, was discussed in a paper from the Swiss P.T.T., who had taken advantage of the Swiss mountains to study the effect of this phenomenon on the frequency spectra of monochrome television signals. A swept frequency oscillator was used at the Band-I transmitter and the disturbances resulting from the multi-path propagation were assessed statistically from measurements at various domestic receivers. It was concluded that for colour television the narrower the bandwidth of the colour signal the better. These effects, of course, are likely to create quite a problem in any future colour services in Bands IV or V.

For colour television recording, a method using a lenticular film was described in a paper from the Eastman Kodak Company. The film has a fine cylindrical lenticular pattern on one side and its emulsion on the other. Three primary colour component images are directed on to the lenticular surface from different angles and they appear on the emulsion as three separate sets of interlaced thin bands—the exposure in each case corresponding to the primary colour content. One big advantage is the speed and simplicity with which the film can be developed and copies can be made.

---

## Electronics in Automation

Viewpoint on the Brit. I.R.E. Convention

**T**HE introduction of digital computers into process control systems was probably the most significant thing discussed at this year's Brit. I.R.E. Convention. Significant, because it is a definite step in the direction of Norbert Wiener's imaginative forecast of ultimate automation to which we drew attention two years ago\*—the overall control and co-ordination of complete factories by electronic systems comparable with large-scale digital computers.

Hitherto digital computers have been isolated in laboratories and business offices and used merely as aids to human calculation. Even when employed for production planning in factories they have needed human supervisors to feed in and take out information. But there are signs of a change in this situation. Already engineers are beginning to explore the possibility of incorporating digital computers directly into control loops so that more variables can be taken into account than by ordinary servo-mechanisms.

Many people think that digital computers are

---

\* "The Automatic Factory," *W.W.* August 1955.

inherently too slow for operation in "real-time" control systems. This idea was refuted by one speaker at the Convention who described a "real-time" digital computer which received its input information from shaft rotations (coded into digital form) and gave an output which directly operated an electro-hydraulic servo-mechanism. The "real time" in this instance did not mean instantaneously but extremely fast—the process of addition, for example, taking only 40 $\mu$ sec.

This high speed was attained by using the "parallel" mode of operation (all digit pulses of a number advancing simultaneously on separate wires instead of in sequence on one wire). The programme of instructions was built into the connections and very little storage capacity was required because of the direct manner of receiving, processing and despatching the numerical data. High-frequency transistors were used for the logical circuits and the whole machine occupied only about one-third of a cubic foot.

The technique of feeding information directly into a digital computer from measuring instruments, instead of via the medium of punched cards on tape, was mentioned by another speaker, who described how an existing business machine (the Elliott "405") was adapted for this purpose. The output, incidentally, was used to operate an analogue type of plotting device.

### Conveyer-belt Systems

In some applications, the "real time" could mean something really slow—for example, in the control of manufacturing processes based on conveyer belts. One of the Convention papers discussed the control of a conveyer-belt system in which the products on the belt could be varied in design (e.g., different paint colours on motor-car bodies) according to the day-to-day fluctuations in demand from customers. In the control apparatus the slow movement of the conveyer belt was simulated by a storage medium moving equally slowly past a complexity of "reading" and "writing" heads connected to the digital computer. Numerically coded information about the items on the belt was "written" by the computer at corresponding places on the storage medium. As a particular item reached a "decision point" on the belt, the stored information on what was to be done at that point came to a reading head, which gave out the appropriate signals for actuating the process.

Another paper considered the use of computers in control systems applied to continuous-process chemical manufacturing plants. Here the object was to keep the plant output as near as possible to a desired specification. The outputs from local control loops already existing in the plant would be continuously monitored in a scanning sequence and compared in the computer with the desired values for the product. According to the results, the computer output would be used to apply correcting signals to the control-loop equipment. It was felt that electronic circuits using such components as transistors and cryotrons would be desirable in this application so that voltages could be kept to low values for safety reasons.

A particular feature of computers used for this type of production control would be a multiplicity of input and output devices distributed about the fac-

tory. One speaker went further and suggested that the computing circuits themselves would probably have to be decentralized and distributed in a similar manner.

In order to feed information from measuring devices into digital computers it is usually necessary to convert an analogue type of indication into digital form. When, say, the angular movement of a shaft has to be measured, this can easily be done by using a commutator disc or "digitizer" on the shaft. When the output of a measuring transducer is in the form of a varying voltage, however, it is necessary to use an all-electronic converter. A high-speed electronic converter described in one paper was basically a servo-mechanism using a non-linear feedback element. The voltage to be measured was compared with a voltage analogue of a number held in a register. Any resultant error signal was used to gate digit pulses into the register in such a way that the error was reduced to zero. Thus the number in the register increased and decreased in accordance with the input voltage variations.

A somewhat sophisticated digital measuring technique described in another paper gave its output as a ratio, or as a percentage of some reference value. For this, independent sources of pulses were counted and then compared. The device was said to have applications in revolution counting and tachometry and where comparative measurements have to be made between driving and driven apparatus. Another rather complex type of digital measurement under discussion was the evaluation of correlation functions from statistical operating data taken from different points in a control system. This could be used, for example, for determining the transfer function of a control system while it was still in operation. Correlation computers are traditionally analogue devices, but greater accuracy can be obtained from digital methods, and a digital machine was described which accumulated the sum of products of pairs of numbers for this type of evaluation. It operated in the decimal scale, using Dekatrons for the arithmetic circuits. Working on pairs of two-digit decimal numbers, it could accumulate 100 products per minute.

### Analogue Techniques ?

The emphasis on digital computers in control loops is perhaps rather unexpected when analogue computers seem at first more obviously suited to the purpose. Analogue computers do have certain applications in continuous-process control loops, but, as one paper pointed out, when the manufactured product consists of a number of items, each with a particular identity, then these machines are quite inappropriate. It is the arithmetical accuracy, ability to perform logical operations and facility for storage of data and instructions which make the digital machine more suited to the complex organization of overall control.

Many other aspects of automatic control and inspection were discussed—machine-tool position control, ultrasonic inspection, pH control, fluid density measurements, to name just a few. It was, however, rather surprising to find a whole day's session devoted to simulators. If these come under the heading of automation then *Wireless World* gives up all hope of discovering what automation really means.

# WORLD OF WIRELESS

## Medical Electronics

AN international organization to foster the application of electronics to medicine is being formed by Dr. V. K. Zworykin, the well-known American pioneer in electronic television. Interviewed recently by *Wireless World* in Paris, Dr. Zworykin said he felt that electronics should be applied more directly than it has been to the benefit of humanity. Already he has been instrumental in establishing a Medical Electronics Centre in the Rockefeller Institute for Medical Research in New York. The aim here is to develop new electronic techniques for the medical world without any form of commercial exploitation and already several devices have been produced on this basis. Dr. Zworykin has also composed a bibliography of medical electronics literature. He hopes to organize an international conference on the subject, possibly at the time of the 1958 Brussels Exhibition.

## Further Education

WITH the opening of the scholastic year in September, we have received prospectuses of radio and electronics courses from a number of polytechnics, colleges and other bodies.

The Northern Polytechnic, Holloway, London, N.7, has introduced a one-year evening course (one evening a week) covering the audio-frequency engineering syllabus, Part 5, for the Brit. I.R.E. Graduate Exam. The television engineering course (evenings) has been extended to two years and now includes the fundamentals of colour systems.

Among the short courses provided at the South-East London Technical College, Lewisham, S.E.4, is again one on transistors and their applications. The College also has a four-year C. & G. electrical technicians' course in which specialization in industrial electronics is provided.

Details of evening courses on v.h.f. techniques, radar maintenance, and radio and television servicing, plus full-time day courses in telecommunication engineering are given in the prospectus issued by the Norwood Technical College, London, S.E.27.

Courses in preparation for the Radio Amateur Examination are again being provided at the Brentford (Middlesex) Evening Institute, Ilford (Essex), Literary Institute and Northwood (Middlesex) Evening Institute.

## NATIONAL RADIO EXHIBITION

(Earls Court, Aug. 28th—Sept. 7th, 11 a.m.—10 p.m.)

### WIRELESS WORLD SHOW NUMBERS

**September: Show Guide** (publication date August 27th). Plan of the stands with stand-to-stand guide to the exhibits.

**October: Show Review** (publication date September 24th). An assessment of trends in the design of television and sound receivers.

## I.E.E. Premiums

APPROXIMATELY a third of the awards made by the I.E.E. for papers read, or accepted for publication, during the 1956-57 session are for contributions in the radio and electronics field.

Two papers on signal-noise ratio in radio-telegraphy have won for H. B. Law, of the G.P.O. Research Station, Dollis Hill, the Kelvin Premium (£25). Mr. Law also shares the Fabie Premium (£10) with his Post Office colleagues, J. W. Allnatt and E. D. J. Jones, for their paper "Frequency diversity in the reception of selectively fading binary f.m. signals."

For their paper "Fading of long-distance radio signals and a comparison of space- and polarization-diversity reception in the 6-18 Mc/s range," Dr. G. L. Gridale (Marconi's), J. G. Morris (Government Communications Headquarters), and D. S. Palmer (Marconi's), receive the Duddell Premium (£20). Professor H. E. M. Barlow (University College, London), is awarded the Ambrose Fleming Premium (£15) for "Hall effect and its counterpart, radiation pressure, in microwave power measurement." There were also ten extra premiums, valued at £5 each, awarded for papers presented to the radio and telecommunication section.

## Tape Exchanges

DURING the past five years various organizations have been formed, both in this country and abroad, to encourage the exchange between individuals of tape recordings.

World Tape Pals, which issues a bi-monthly publication *Tape Topics*, was founded in Dallas, Texas, in 1952. The British representative is Roger D. Smallwood, of 28, Wrekin Road, Sutton Coldfield.

The only British organization is the recently formed British Amateur Tape Recording Society, of which E. Yates, of 210, Stamford Road, Blacon, Cheshire, is general secretary. The society is issuing a tape-recorded bulletin—playing time, one hour—and also a quarterly tape "magazine" for blind members.

B.A.T.R.S., the Voicospence Club (Noel, Va., U.S.A.), and the Australian Tape Recordists Association (Adelaide), are the founder members of the International Association of Recording Clubs.

In addition to the American clubs already mentioned there are Tape Respondents International, United Recording Club, International Tape Worms, and National Tapespinners.

**Amateur Recording Contest.**—Copies of the rules and entry forms for the Concours International du Meilleur Enregistrement Sonor, which is organized by the world's amateur recording associations, are obtainable from H. J. Houlgate, 12, Strongbow Road, London, S.E.9, on receipt of a stamped addressed envelope. Last year two British entries won prizes in this international contest organized to find the best amateur examples of recording techniques for various subjects. The closing date for entries is September 15th.

**I.G.Y. Broadcasts.**—Warnings of expected increases in solar activity and declarations of Special World Intervals, issued by the Royal Society during the International Geophysical Year, are being broadcast by the B.B.C. at 11.03 p.m. in the Home Service after the news and before the weather forecast. These announcements supplement the communications system already established by the World Warning Agency.

**Test transmissions** from the site of the I.T.A. station being built at St. Hilary, Glamorgan., to serve South Wales and the West of England will start on September 2nd. The station will operate in Channel 10 (199.75 Mc/s vision, 196.25 Mc/s sound). The test transmissions will be radiated from an aerial mounted at a height of about 350 feet on the partially completed 750-foot mast, and will have an e.r.p. of about 1 kW. It is hoped to start programme transmissions from the station before Christmas.

**Scottish Television.**—With the opening on August 16th of the B.B.C.'s television station at Rosemarkie, near Inverness, the coverage of the Scottish television service will increase to 93% of the population. The station, which is the B.B.C.'s seventeenth, will operate in Channel 2 (vision 51.75 Mc/s, sound 48.25 Mc/s) with horizontal polarization and an e.r.p. of 1.5 kW. Test transmissions will be radiated from 10.0 a.m. to 1.0 p.m. each weekday from July 31st until the station is brought into service.

**Welsh V.H.F.**—A site at Cynr-y-Brain, near Llangollen, Denbigh, has been chosen by the B.B.C. for the north-east Wales v.h.f. sound transmitter. It is expected that the station will be brought into service by the autumn of next year. It was originally intended to build the station at Corwen, Merioneth., and to transmit only the Welsh Home Service, but it is now planned as a three-programme station radiating on 88.9, 91.1 and 93.3 Mc/s with an e.r.p. of 6 kW.

**Television licences** increased by 68,390 during May bringing the total to 7,118,698. The overall number of broadcast receiving licences in the United Kingdom, including those for television and 312,528 for car radio, was 14,583,256 at the end of May.

**1958 Audio Fair.**—Next year's London Audio Fair will again be held at the Waldorf Hotel, but it will be for five days instead of four (April 18th to 22nd). A day will be reserved for trade buyers, overseas visitors and the press.

**Northern Audio Fair.**—Plans are being made to hold a three-day Audio Fair at the Grand Hotel, Harrogate, from October 25th. Particulars of this show and next year's London fair are obtainable from Audio Fairs, Ltd., 42, Manchester Street, London, W.1.

**Band IV television** from the Television Society's transmitter installed at the Norwood Technical College are being discontinued during the summer vacation, but will be resumed on September 9th. The transmissions, which are radiated on 427 Mc/s, vision, and 423.5 Mc/s, sound, and consist of Test Card C and a tone, will be on Mondays, Wednesdays and Fridays from 7.0 till 9.0.

**Mobile Radio.**—Reference was made at the British Electrical Power Convention at Eastbourne to the growing use of v.h.f. radio-telephony by the electricity supply industry. There are now 99 fixed stations and well over 1,000 mobile transmitters in use by electricity boards.

**Amateur Television.**—There are now 32 amateur television transmitting stations in the U.K. A list of call signs and locations is given in the summer edition of *CQ-TV*, issued by the British Amateur Television Club.

**Circuit details**, or instruction manual, of the Eddy-stone 358X receiver is being sought by a reader. Information should be addressed to M. Osborne, c/o The Editor.

**Electronic Telephone Exchanges.**—The Post Office has entered into an agreement with five telephone equipment manufacturers for the pooling of ideas with the object of "designing the best possible electronic switching system," and to this end a research committee has been set up under the chairmanship of the Post Office engineer-in-chief. This is recorded in the annual report of the Telecommunication Engineering and Manufacturing Association.

**Computer Society.**—Last year the London Computer Group was formed and from this has now grown the British Computer Society with headquarters at 29, Bury Street, St. James's, London, S.W.1. The primary object of the Society is to "further the development and use of computational machinery." Among the members of the provisional council is Dr. A. D. Booth, of the Birkbeck College Computational Laboratory.

**Computer Exhibition.**—Plans for this country's first Electronic Computer Exhibition, to be held at Olympia, London, from November 28th to December 4th next year, include an international technical symposium organized by the National Physical Laboratory. It is also proposed to hold a business computer symposium arranged by the sponsors of the exhibition, the Radio Communication and Electronic Engineering Association and the Office Appliance and Business Equipment Trades Association. Incidentally, the Exhibition is non-profit making and any excess of receipts over expenditure is to be returned to exhibitors.

**Thorn-Champion.**—Rumoured change of ownership of the Champion Electric Corporation was confirmed when Thorn Electrical Industries (makers of Ferguson receivers) announced on July 8th their acquisition of a group of three companies—Champion Corporation, Newhaven Cabinet Works, Ltd., and Austin Clark (London), Ltd.

**Thorn-Bendix.**—An agreement with Bendix Aviation Corporation, of the U.S.A., permits Thorn Electrical Industries to manufacture the Bendix range of A.N. Pigmy and Unitor connectors.

**Soviet Television.**—According to a note in *Soviet News*, which is issued by the Soviet Embassy in London, the U.S.S.R. now has 24 television stations and a further ten will be opened this year. In April there were about 1.5M television receivers in the Union.

"**Operation Smoke-Puff**" is the title given to a series of tests being undertaken in the United States to establish two-way radio communication by reflecting signals from man-made ionized clouds produced by releasing nitric oxide gas from rockets. Members of the American Radio Relay League are participating in the tests which are sponsored by the U.S. Air Force.

**Audio Engineering.**—This year's convention of the Audio Engineering Society of America, at which some fifty papers will be presented, is to be held in conjunction with the New York High Fidelity Show. Both will be held in the New York Trade Show Building from October 9th to 12th.

**U.S. Electronics Conference.**—The 13th annual National Electronics Conference will be held from October 7th to 9th at the Hotel Sherman, Chicago. Information on the Conference and the associated exhibition is obtainable from the N.E.C., 84 E. Randolph Street, Chicago 1, Illinois, U.S.A.

**Interkama**—an International Congress and Exhibition of Measuring Instrumentation and Automation—is being held in Düsseldorf, West Germany, from November 2nd to 10th. Particulars are obtainable from Nordwestdeutsche Ausstellungsgesellschaft m.b.H., Ehrenhof 4, Düsseldorf.

**I.E.E. Students.**—The 1957-58 chairman of the London Graduate and Student Section of the I.E.E. is F. L. Fielding, of Standard Telephones & Cables, and the honorary secretary, L. A. Harris, of Marconi's.

**I.E.E. Council.**—The new president of the I.E.E. is T. E. Goldup, a director of Mullard, and Dr. Willis Jackson, director of research and education, Metropolitan-Vickers, is elected a vice-president for the second term of three years. Those elected to fill the vacancies among the ordinary members of the council include F. C. McLean, deputy chief engineer, B.B.C., and C. E. Strong, chief radio engineer, Standard Telephones & Cables, who was a member of the council from 1949 to 1953.

**Radio Section Committee.**—The new chairman of the committee of the I.E.E. radio and telecommunication section is Dr. J. S. McPetrie, and the new vice-chairman M. G. L. Pulling. The three vacancies among the ordinary members of the committee will be filled by R. J. Halsey, an assistant engineer-in-chief at the G.P.O., Dr. B. G. Pressey (Radio Research Station, Slough), and W. E. Willshaw (G.E.C.).

**B.S.R.A. Committee.**—New members of the executive committee of the British Sound Recording Association are F. Langford-Smith, appointed a vice-president, and G. W. Higgs, E. F. R. Lilley and C. W. Morle elected members. J. F. Doust continues as president.

**C. and G. New Headquarters.**—A site has been secured at 76-78, Portland Place, London, W.1, together with the premises at the rear, for the new headquarters of the City and Guilds of London Institute. It is planned to be ready for occupation early in 1959.

**"Foreign Attachments."**—In the past telephone users in the U.S.A., as in this country, have not been permitted to fit "foreign attachments" to telephone instruments except in certain circumstances. The Federal Communications Commission has, however, now ruled that the telephone companies must permit the use of devices which do not impair the operation of the telephone service.

**Recommended materials and finishes** for telecommunication and allied electronic equipment and components are listed under "new work started" in *B.S.I. News* issued by the British Standards Institution.

## FORTHCOMING EVENTS

<b>National Radio Show (R.I.C.)</b> Earls Court, London, S.W.5.	Aug. 28-Sept. 7
<b>Engineering, Marine, Welding &amp; Nuclear Energy Exhibition</b> Olympia, London, W.14.	29-Sept. 12
<b>Farnborough Air Show (S.B.A.C.)</b> Farnborough, Hants.	Sept. 3-9
<b>British Sound Recording Association Exhibition and Convention.</b> Waldorf Hotel, London, W.C.2.	Sept. 20-22
<b>Conference on Automatic Measurement of Quality in Process Plants</b> (Society of Instrument Technology), University College, Swansea, Glamorgan.	Sept. 23-26
<b>Radio Hobbies Exhibition (R.S.G.B.),</b> Royal Horticultural Society's Old Hall, London, S.W.1.	Oct. 23-26

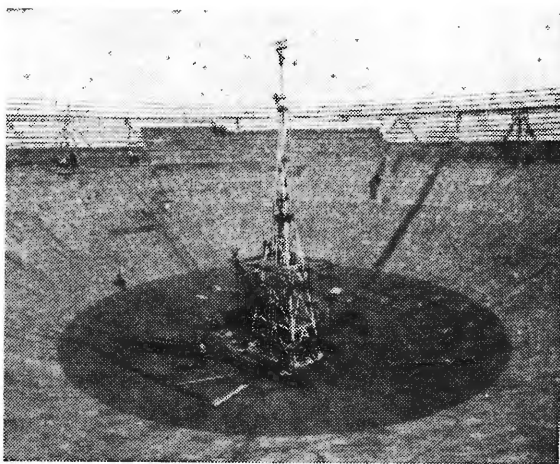

**RADIO TELESCOPE**—The interior of the 250ft diameter bowl of the fully steerable radio telescope at Jodrell Bank, Manchester (now nearly complete), showing the 60ft aerial mast with two dipoles at right angles for simultaneous observation on 90 and 170 Mc/s.

## PERSONALITIES

**T. E. Goldup, C.B.E.,** elected president of the Institution of Electrical Engineers for 1957/58, is a director of Mullard, which he joined in 1923. He had been a vice-president of the Institution since 1952. Mr. Goldup is particularly interested in technical education and training, and has been a member of the board of governors of the Ministry of Supply's College of Electronics, Malvern, since 1949, and chairman of the board since 1952. Mr. Goldup, who was appointed C.B.E. in 1954, was from 1950 to 1954 a member of the Radio Research Board of the Department of Scientific and Industrial Research.



**J. S. McPetrie, Ph.D., D.Sc.,** the new chairman of the committee of the radio and telecommunication section of the I.E.E., has been head of the radio department of R.A.E., Farnborough, since 1950. For the previous six years he was superintendent, signals research and development in the Ministry of Supply, prior to which he was for a short time radio-physicist on the staff of

the British Joint Services Mission in Washington. From 1925 to 1943 Dr. McPetrie was at the National Physical Laboratory.

**M. J. L. Pulling, O.B.E., M.A.,** who becomes vice-chairman of the I.E.E. radio and telecommunication section, has been senior superintendent engineer (television) with the B.B.C. since 1949. After leaving Cambridge University in 1929 he went into industry and was for a few years with Murphy Radio, where he was in charge of production testing. He joined the engineering division of the B.B.C. in 1934 and was for eight years superintendent engineer (recording) prior to being appointed to his present position.

**J. N. Aldington, B.Sc., Ph.D., F.Inst.P., M.I.E.E.,** managing director of the new company Siemens Edison Swan, Ltd., joined Siemens at Preston in 1923 as an analytical chemist in the lamp works laboratory. Dr. Aldington was appointed head of the company's lamp research laboratories in 1935 and in 1949 was elected to the board of Siemens Electric Lamps and Supplies, Ltd. Three years later he became managing director of the company, and when, in 1955, it ceased to act autonomously, he became managing director of Siemens Brothers, the parent company. He is also chairman of Submarine Cables, Ltd., which is jointly owned by Siemens Edison Swan and the Telegraph Construction and Maintenance Company.

In addition to those mentioned last month, **Air Commodore A. V. Harvey, C.B.E., M.P.,** a director of Mullard, Ltd., since 1950, was created a Knight Bachelor in the Birthday Honours, and **J. A. Dunkley,** senior development and experimental engineer at R. B. Pullin & Company, was appointed M.B.E.



# News from the Industry

**Siemens Brothers & Company and the Edison Swan Electric Company** have now finally been merged into a single company to be known as Siemens Edison Swan, Ltd. It will be recalled that in 1955 Siemens Brothers joined the Associated Electrical Industries group of companies, of which Edison Swan has been a member since 1928, and that last year a temporary company, Siemens-Ediswan, Ltd., was set up to co-ordinate the activities of the two companies. The new company, of which Dr. J. N. Aldington is managing director, has been divided into 18 "product divisions," each specializing in a particular type of equipment. Each division will have a chief engineer, manufacturing manager and sales manager, but there will be a single research organization for which three blocks of buildings are being built at Harlow New Town, Essex. The director of research is Dr. T. E. Allibone.

**British Tungfram Radio Works, Ltd.**, West Road, Tottenham, London, N.17, announce that in consequence of the merger, of Siemens and Edison Swan, Tungfram valves will no longer be distributed by Siemens but by its own distribution organization.

**British Communications Corporation** have been awarded a contract for the supply of a large quantity of multi-channel recording equipment for the Ministry of Transport and Civil Aviation. The equipment, which will be used for air traffic control, provides for the simultaneous recording of up to twenty channels on a single tape.

**Avo, Ltd.**, is the new name adopted by the Automatic Coil Winder & Electrical Equipment Company, manufacturers of the well-known series of Avo test and measuring instruments and Douglas coil-winding equipment.

**Amphenol (Great Britain), Ltd.**, has been formed jointly by Gas Purification and Chemical Company and Amphenol Electronics Corporation (of Chicago) for the handling of Amphenol components in the British Commonwealth (except Canada) and on the Continent. Initially components will be imported, but it is planned eventually to manufacture in this country. Among the subsidiaries of Gas Purification and Chemical Company are Grundig (Great Britain), Wolsey Television and A.B. Metal Products.

**Livingston Laboratories**, of Retcar Street, London, N.19, have been appointed exclusive sales representatives for the United Kingdom by Hewlett-Packard Company, of Palo Alto, California.

**Battery-operated industrial television** equipment was recently installed experimentally in a Swiss train by Pye. Tests were conducted to assess the possibilities of its use for examination of inaccessible parts of the train especially whilst in motion.

**Metro-Sound Manufacturing Company** has been formed by M. S. Myers (until recently with Goldring Manufacturing Company) for the manufacture of gramophone accessories. The address is 64, Stoke Newington High Street, London, N.16 (Tel.: Clissold 1549).

**Radio Heaters, Ltd.**, manufacturers of Radyne radio-frequency heating equipment, have opened a new research laboratory at Wokingham, Berks, where they have their works. The services of the laboratory will be available to any potential industrial user of r.f. induction and dielectric heating equipment.

**Plessey Company** have transferred the production of their standard communication equipment from Ilford, Essex, to West End Mills, St. Ives, Hunts. (Tel.: St. Ives 2095.) P. A. Tremaine remains as unit manager.

**Morganite Resistors, Ltd.**, announce the appointment of M. G. B. Mason as general sales manager and of Dr. W. W. Marshall, as manager of their technical department.

**Marconi Instruments** are building an extension to their factory at Longacres, St. Albans, Herts., which will provide an additional 22,000 square feet of manufacturing space.

## EXPORT NEWS

**G.C.A.**—Three British manufacturers working together have secured a contract for the supply and installation of a complete ground-controlled approach system for one of the airfields of the Royal Rhodesian Air Force. Standard Telephones and Cables are responsible for the overall planning of the G.C.A. installation and are supplying the precision approach radar, Cossor are manufacturing the surveillance radar and International Aeradio are supplying the control and communication equipment.

**Public address equipment**, incorporating facilities for simultaneous interpretation, for the new Paris headquarters of U.N.E.S.C.O. is to be supplied by Pamphonic Reproducers.

**Electronic control equipment** for machine tools is being shown by E.M.I. Electronics at the Machine Tool Exhibition to be held in Hanover, West Germany, in September.

**Electro-acoustic apparatus**, including domestic broadcast receivers and sound reproducing equipment, is amongst the consumer goods to the value of nearly £6M which Yugoslavia is permitting to be imported this year. The names and addresses of Yugoslav organizations participating in the scheme are obtainable from the Board of Trade, Commercial Relations and Exports Dept., Horse Guards Avenue, London, S.W.1. (Ref. C.R.E. 5919/56.)

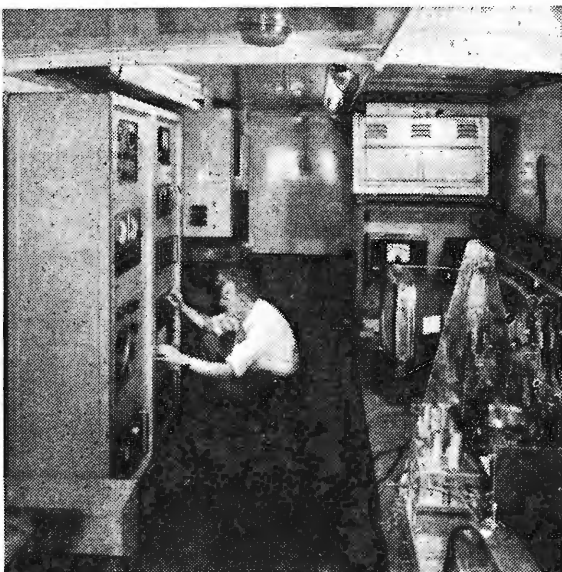

*ON THE SPOT investigations, to check the results of laboratory work on a.g.c. systems for 625-line television receivers, are being undertaken on the Continent by Mullards with a mobile experimental unit. The comprehensive equipment in the vehicle, which carries an extendible aerial system for Bands I and III, includes a line selector unit for the analysis of individual line waveforms and a line pulse generator used for measuring flywheel sync characteristics.*



# An Alternative Colour TV System

By E. J. GARGINI\*

BETTER QUALITY REPRODUCTION  
FROM NON-REDUNDANT COLOUR  
INFORMATION

HERE is a great temptation in Britain to adopt the American N.T.S.C. colour television system—suitably modified for 405-line standards—exactly as it stands. This would be very unwise, however, until the details of the system have been critically examined, particularly in the light of recent developments.

The author has been investigating colour systems with the ultimate aim of finding the best method of transmission to result in a simple and cheap domestic receiver—on which the success of colour television so much depends. In the course of this work several deficiencies of the N.T.S.C. system have come to light, and these have led to a proposal for an improved alternative system using a fundamentally different method of transmitting the colour information. However, the broad principle by which the N.T.S.C. system obtains its compatibility is retained—that of transmitting a luminance, or brightness, signal in the correct form for monochrome receivers, together with a colour signal providing the additional hue and saturation information required for colour receivers.

Three major features of the N.T.S.C. system are open to criticism, and these have already been discussed in *Wireless World*†. The first is the nature of the colour signal. This signal conveys colour-difference information—that is, differences from

white—and is formed from colour-difference components  $E_R - E_Y$ ,  $E_G - E_Y$  and  $E_B - E_Y$  (where  $E_R$ ,  $E_G$  and  $E_B$  are the red, green and blue camera-tube outputs and  $E_Y$  is the luminance or “whiteness” signal). As colours become more saturated for a given brightness level, the  $E_R$ ,  $E_G$  and  $E_B$  camera outputs become larger and more significant in the  $E_R - E_Y$ ,  $E_G - E_Y$  and  $E_B - E_Y$  colour-difference signals, while the  $E_Y$  signal remains constant. Thus, any brightness detail in a saturated colour (e.g., dark shadows on a bright red curtain) will produce larger amplitude changes in the appropriate colour-difference signals than with a less saturated colour (e.g., the same shadows on a pale red curtain of equal brightness). In other words, the brightness information, which properly belongs in the luminance channel, is carried increasingly by the colour signal. Since in the N.T.S.C. system the colour signal is band-limited by filters to give a narrow-band colour signal—and hence slower rates of change—the result is that with saturated colours a good deal of the brightness detail (to which the eye is particularly sensitive) is completely lost.

In the proposed alternative system this particular disadvantage is avoided by transmitting a colour signal which carries no redundant brightness informa-

\* E.M.I. Research Department.  
† “N.T.S.C. Colour Information,” by E. L. C. White, February, 1957, issue.

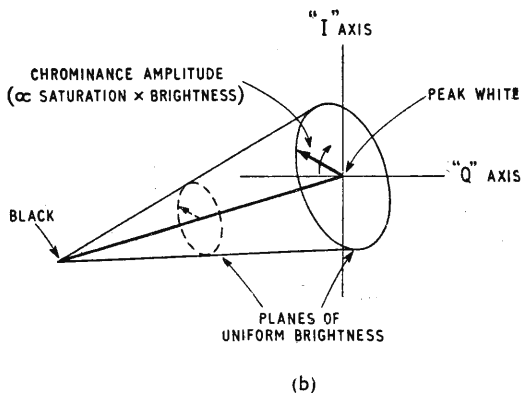
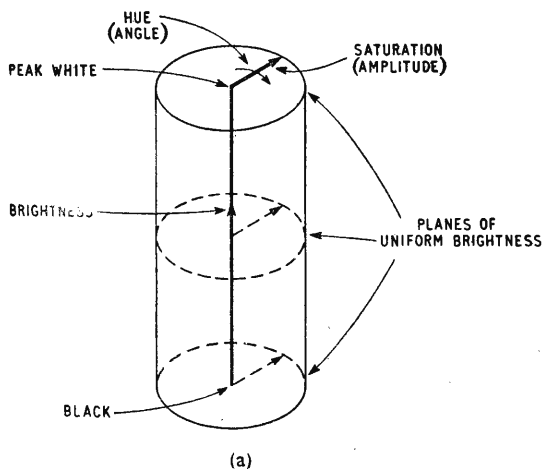

Fig. 1. Three-dimensional vector diagrams illustrating the difference between a chromaticity signal (a) and a chrominance signal as used in the N.T.S.C. system (b).

tion. Consequently only true colour information—that is, hue and saturation—is conveyed. For this reason the colour signal is called a *chromaticity* signal, as distinct from the *chrominance* signal of the N.T.S.C. system. The difference between the two is illustrated by the three-dimensional vector diagrams in Fig. 1. Here the colour signal vector represents hue by its phase angle and saturation by its amplitude. In the chromaticity signal (a) the colour signal amplitude is not influenced by different brightness levels, but in the chrominance signal (b) the amplitude is determined partly by the colour content and partly by the brightness.

### Gamma Correction

The second feature of the N.T.S.C. system under criticism is the composition of the luminance signal. This is formed from a mixture of the red, green and blue camera-tube outputs (actually  $E_y = 0.59E_G + 0.3E_R + 0.11E_B$ ) which are first individually gamma-corrected. The fact that an inverse square-law correction is applied to the individual components of the luminance signal at the transmitter leads to inaccuracies in the displayed luminance information at the receiver. Moreover, if the individual gamma corrections are not balanced properly the displayed colours will alter in hue and saturation at different intensity levels. This problem does not arise in the improved alternative system, since the luminance signal is gamma-corrected after formation.

The third questionable feature of the N.T.S.C. system is the use of a sub-carrier inside the normal monochrome vision band. In American receivers it is well known that the video response is substantially reduced at the sub-carrier frequency so the effect of interference from the colour signal is not very severe. In addition, although the so-called "I" modified colour-difference signal has extended sidebands to convey the more detailed information which the eye can appreciate at the red end of the optical spectrum‡, this extra information is not, in fact, utilized in current receivers.

Consequently the N.T.S.C. system as used in America is not really a band-sharing system, but one in which colour information is virtually transmitted outside the monochrome band in the unused area close to the sound carrier. If the system were adopted in Britain, however, the wider bandwidth

of the average domestic model would insufficiently attenuate the colour sub-carrier and thus permit a display of dot patterning.

Although this may not be a severe price to pay for colour broadcasting, the fact that the colour receiver must treat the colour transmission as an outside-the-luminance-band transmission, means that the luminance detail at the colour receiver is restricted. This band restriction comes about because the sub-carrier itself must not appear at the colour receiver c.r.t. control electrodes otherwise it will increase the brightness of the colour components upon rectification in any particular electron-gun assembly. Moreover, if the guns are in any way fed with unequal amounts of colour sub-carrier the colour balance will no longer be maintained at different brightness levels.

A further difficulty arises because in practice it is necessary to use a "notch" filter at the transmitter to prevent those brightness transients which produce components at frequencies close to the colour sub-carrier from beating with the receiver's synchronous-detection local oscillator and so causing low-frequency colour beat patterning. This filter inevitably reduces the bandwidth of the brightness signal.

If it were possible to use a 3-Mc/s colour sub-carrier in Britain, however, instead of one at 2.66Mc/s, most domestic receivers would display very little dot patterning. This, in fact, is what is proposed in the alternative system. Moreover the "notch" filter mentioned above is not necessary because the low-frequency colour beat patterning is reduced by other means. In the N.T.S.C. system the interaction between the brightness transients and the colour sub-carrier actually occurs because the sub-carrier is positioned in the single-sideband part of the monochrome band. This is avoided in the alternative system by removing from the colour signal the component most susceptible to interference—the hue information—and transmitting it over the double-sideband part of the monochrome band around the main carrier. It is clearly not possible to have a sub-carrier at the same frequency as the main carrier, so the method adopted is to transmit the change of hue angle by phase modulation of the main carrier. The 3-Mc/s sub-carrier is then merely concerned with conveying the saturation information—transmitted by amplitude modulation.

The complete signal of the alternative system has a frequency spectrum as illustrated in Fig. 2. Summarizing the situation, it can be said that the chromaticity information to be transmitted is separated into its two components, hue and saturation, and the hue is conveyed by phase modulation of the main carrier and the saturation by amplitude modulation of a 3-Mc/s sub-carrier just outside the normal monochrome video band.

It will be noted, first of all, that the chromaticity signals are restricted in bandwidth, compared with the luminance signal, in the same way as the chrominance signals in the N.T.S.C. system. This restriction takes advantage of the general principle that the eye is less sensitive to small colour detail than it is to small brightness detail, and that a sharp colour picture can be synthesized by combining blurred, or narrow-band, colour information with sharp or wide-band, brightness information.

Actually the rate-of-change of hue information has been restricted to a bandwidth corresponding to that

‡ The other modified colour-difference signal, called the "Q" signal has a narrower bandwidth and conveys the less detailed information required at the blue end of the optical spectrum.

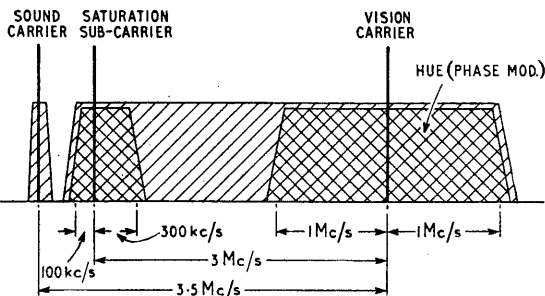
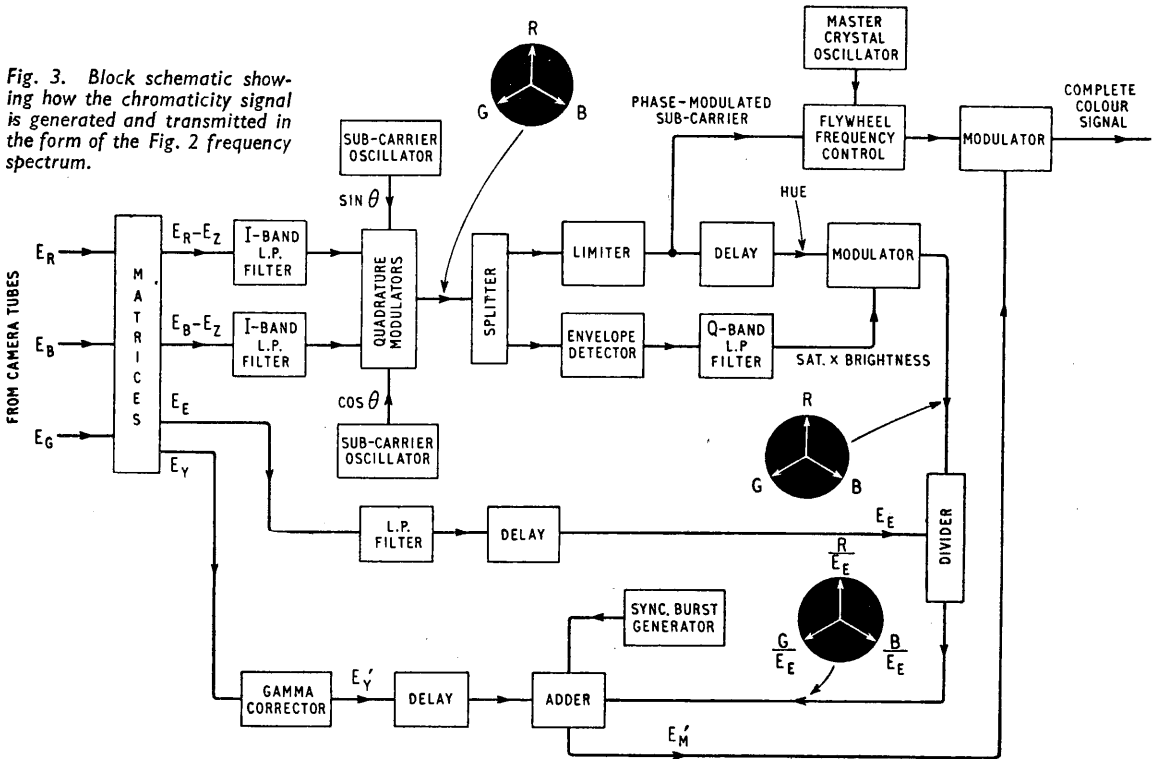

Fig. 2. Frequency spectrum of the proposed alternative system. The sub-carrier is at 3Mc/s instead of 2.66Mc/s as in the British N.T.S.C. system.

Fig. 3. Block schematic showing how the chromaticity signal is generated and transmitted in the form of the Fig. 2 frequency spectrum.



of the "I" modified colour-difference signal in the N.T.S.C. system, and the rate-of-change of saturation to a bandwidth corresponding to that of the "Q" modified colour-difference signal. This has been arranged purely for the purpose of comparative tests with the N.T.S.C. system. The fact that the saturation component is assigned the narrower band is mainly a matter of expediency—and it provides another reason why the transient hue information should be phase modulated on to the main carrier. With this arrangement it will be noted that the transmission of the colour information corresponds to the colour vector diagram in Fig. 1(a)—the hue being represented by angle or phase and the saturation by amplitude.

### Signal Synthesis

It now remains to be shown how the chromaticity signal is manufactured in the form of hue and saturation components and how these are combined with the luminance information to form the complete colour signal in Fig. 2. A block schematic of the system is shown in Fig. 3. To begin with, the red, green and blue camera-tube outputs,  $E_R$ ,  $E_G$  and  $E_B$ , are passed into proportional adding circuits known as matrices. Various proportions of these voltages are then combined to form three brightness type signals. The first is a luminance signal  $E_Y$ , as in the N.T.S.C. system ( $E_Y = 0.59E_G + 0.3E_R + 0.11E_B$ ), the second is an "equal-energy" brightness signal,  $E_B$ , formed from equal amounts of the three camera outputs ( $E_B = (E_R + E_G + E_B) \div 3$ ), while the third,  $E_Z$ , has a special composition which will appear shortly.

This  $E_Z$  signal is subtracted from  $E_R$  and  $E_B$  to

form two colour-difference signals  $E_R - E_Z$  and  $E_B - E_Z$ , as shown. These are passed through low-pass filters which limit them both to a bandwidth corresponding to that of the I signal in the N.T.S.C. system. The two colour-difference signals are then used to amplitude modulate two components of a 3-Mc/s sub-carrier having a phase difference of  $90^\circ$  between them. The two modulated components are combined to produce a single chrominance-type signal at 3Mc/s which conveys hue information by its phase angle and saturation and brightness information by its amplitude. It differs from the N.T.S.C. chrominance signal, however, in that the composition of the  $E_Z$  signal is arranged so that the phase angles which represent the three primaries, red, green and blue, are equally spaced at  $120^\circ$  intervals. This arrangement is called a *symmetrical* colour-difference signal.

The symmetrical signal is passed to a splitter unit, one output of which is taken through a delay device, and the other to an amplitude detector. The output of this detector is the saturation  $\times$  brightness component of the colour signal (see Fig. 1(b)) and has the character of a video type of signal. As the  $E_R - E_Z$  and  $E_B - E_Z$  components have been passed through "I-bandwidth" filters before modulation, it follows that the chrominance signal will possess phase and amplitude changes which are related to the rise times of the two component voltages. The detected saturation signal will therefore have a rise time which depends on the rise time of the original I-bandwidth modulation signals. Consequently this signal should be passed through a narrow-bandwidth filter to restrict the saturation  $\times$  brightness amplitude rates of change to that of the Q band if a narrow-band saturation signal is desired as in Fig. 2.

The hue signal is formed by passing the chrominance signal from the splitter into a limiter circuit which limits on the first perceptible colour change from white (i.e., from zero amplitude). The output of this limiter, therefore, for any picture element other than white is a continuous 3-Mc/s signal, the phase of which is determined by the hue of the transmitted colour. This signal is next passed through a delay network to ensure that hue changes occur in step with the corresponding saturation changes and finally the restricted saturation signal is used to remodulate in amplitude the steady-amplitude hue carrier. A chrominance-type signal is thus re-formed which has the special feature that hue angle changes occur at a rate determined by the I bandwidth and saturation amplitude changes at the slower rate fixed by the Q bandwidth.

### Segregating Colour Information

This signal now has to be converted from a chrominance-type signal, containing redundant luminance information, into a chromaticity signal. What is required is to remove the inherent modulation due to the brightness changes, and this is done by arithmetically dividing the instantaneous value of the chrominance signal by the instantaneous value of the  $E_B$  brightness or intensity signal occurring at the same time $\S$ . In other words, any changes due to brightness in the chrominance-signal "numerator" are automatically cancelled out by the same brightness changes in the "denominator," leaving just the changes due to pure chromaticity information.

Since the brightness rates-of-change in the "numerator" have already been restricted by a Q-bandwidth filter (used on the saturation  $\times$  brightness information to give a narrow-band signal), it is obviously necessary to restrict the brightness rates-of-change in the "denominator" in the same way. This is achieved by passing the  $E_B$  signal through a low-pass Q-bandwidth filter, as shown, before it goes to the dividing circuit. (It is also passed through a "trimming" delay line to keep it in step with the "numerator" brightness changes.)

As a result of the division process a true chromaticity signal is produced, consisting of a 3-Mc/s oscillation modulated in phase by hue changes and in amplitude by saturation changes. It now remains to be shown how the hue and saturation components are separated as in Fig. 2. In the first place the 3-Mc/s chromaticity signal is added to the  $E_Y$  brightness signal (after the last-mentioned has been gamma-corrected), together with short bursts of sub-carrier frequency for colour synchronizing purposes. This gives the combined signal  $E_{M'}$ , which can be expressed mathematically as

$$E_{M'} = E_Y^{1/\gamma} + \frac{\sqrt{(E_R - E_Z)^2 + (E_B - E_Z)^2}}{E_B} \sin(\omega t + \theta)$$

where  $\theta = \tan^{-1}(E_R - E_Z)/(E_B - E_Z)$ , representing the changes of the hue phase angle.

The hue information, provided by the phase angle of the limited 3-Mc/s sub-carrier, is phase modulated on to the main vision carrier by means of a flywheel frequency control circuit $\parallel$ , as shown,

and the output of this is in turn amplitude modulated by the  $E_{M'}$  signal. As a result of modulating an already phase-modulated carrier wave with the phase-modulated 3-Mc/s sub-carrier contained in the  $E_{M'}$  signal, the transient phase modulation of the 3-Mc/s sub-carrier disappears. There remains only the saturation amplitude modulation of the sub-carrier, which appears as in Fig. 2.

Having transmitted a signal of the form shown in Fig. 2, we may now consider briefly the situation at the receiving end of the system. After the complete colour signal has passed through the usual r.f. and i.f. stages it is fed to a detector, which recovers the  $E_{M'}$  signal as already defined—that is, an  $E_Y$  brightness signal plus a symmetrical chromaticity signal in which hue changes are I-bandwidth and saturation changes are of Q-bandwidth. Although originally the sub-carrier, considered as a transmitted signal, was modulated with the saturation signal only, the effect of heterodyning the steady-phase saturation signal against the hue phase-modulated main carrier at the  $E_{M'}$  detector is to transfer automatically all the hue phase modulation, transmitted double sideband, to the sub-carrier signal.

This symmetrical chromaticity signal is synchronously detected, using a local 3-Mc/s reference oscillator, and the outputs are multiplied by an "equal-energy" brightness signal of the form  $E_B$  (necessary because of the division process at the transmitter). These operations subsequently yield the original  $E_R$ ,  $E_G$  and  $E_B$  voltages which may be applied to the colour display device. The  $E_B$  signal at the receiver is actually derived by a converter circuit $\parallel\parallel$  from the received  $E_Y$  signal.

### Lower Receiver Costs

It will be noted, incidentally, that the rate of change of colour information is determined by the transmitter filters, and no expensive filters or delay lines are required at the receiver. Nor is there any need, in certain receivers with single-gun colour tubes, for matrices as used in the N.T.S.C. system receivers. As far as the average monochrome receiver is concerned, there is substantially no sub-carrier to cause visual interference at the reproducing tube because of the considerable drop in the receiver's video response at 3Mc/s.

It would be an advantage in an alternative system to dispense with the colour sub-carrier altogether. This could be achieved by using the existing sound carrier as the colour sub-carrier as well as for conveying its own sound information. This is not possible with the existing 405-line system, in which the sound signal is broadcast as an amplitude modulation of the sound carrier. It is possible, however, to consider the inauguration of a new high-definition service in Band IV or V in which a number of changes could be made. For example, a 625-line system with brightness signals transmitted in the conventional vestigial side-band fashion, the hue component of the colour signal transmitted as phase modulation of the main vision carrier, the saturation signal transmitted as an amplitude modulation of the sound carrier, and the sound signal transmitted by the conventional 75-kc/s deviation of the f.m. sound carrier.

$\S$  British Patent Application No. 10976/56.

$\parallel$  British Patent Application No. 19201/56.

$\parallel\parallel$  British Patent Application No. 6576/57.

# Ionospheric Problems

By T. W. BENNINGTON\*

## APPLICATION OF IGY DATA TO RADIO COMMUNICATION

**M**ANY geophysical phenomena are to be specially investigated during the course of the International Geophysical Year and among them are to be found several appertaining directly or indirectly to the ionosphere. From 1st July, 1957 to 31st December, 1958, ionospheric measurements of different kinds, and observations upon extra-terrestrial phenomena which affect the region, are to be made upon a world-wide scale, and from the mass of data thus accumulated it is hoped that much will be learned.

Our present knowledge of the ionosphere has been built up largely on the basis of the information obtained by the use of exploring radio waves; but much may be missed by such a process, for the echoes bring little information about the regions lying between the points where ionization maxima exist. Knowledge of the conditions within such regions is arrived at largely by deduction, which may not always be correct. Rocket flights into the ionosphere give different ideas as to the distribution of ionization with height, but the information so far obtained in this way is sparse. It is well, therefore, that the "radio" measurements to be made during the IGY will be supplemented by those obtained by flights into, and perhaps beyond, the ionospheric regions.

The IGY is, of course, mainly a scientific project, aiming to obtain more knowledge of the physical nature of the earth and its atmosphere and of the extra-terrestrial phenomena which affect them. But it is hardly conceivable that the ionospheric and other data obtained by this effort will not have direct application to the engineering problems of long-distance communication. And it must be admitted that communications engineers are sorely in need of more ionospheric information, for it cannot be claimed that their present techniques for making use of the ionosphere are by any means completely satisfactory. In this article, therefore, we will discuss one or two outstanding ionospheric problems which are of direct consequence in radio communication. "Sporadic E". One feature of the E layer about which little is known is that of the localized "clouds" of high ionization which frequently occur within the layer, and which are known collectively as "Sporadic E". This remains as perhaps the outstanding mystery of the ionosphere, for no real notion as to its cause yet exists.

The high ionization density of the sporadic E clouds are capable of reflecting radio waves of much higher frequency than is the normal layer. In fact, their ionization density is often high enough to "blanket" the wave from the  $F_2$  layer, which lies higher up, and which would normally be the refracting medium for the wave in long-distance communication. Fig. 1 shows the highest frequencies which would have been reflected from the E,  $F_2$  and sporadic E at oblique incidence during a day in June, as obtained from the vertical incidence ionospheric measurements made at a mid-latitude northern hemisphere station. It is true that during June sporadic E is

especially prevalent in such latitudes, but it is seen that, for the greater part of the day, its MUF (maximum usable frequency) was far higher than that for the other layers. Thus, the sporadic E can modify the transmission mechanism for long distances in an important manner.

Over most of the earth's surface the sporadic nature of this phenomenon is most marked: it appears to form for no apparent reason, remain in being for up to several hours, then decrease in intensity and disappear. Nevertheless, in spite of this, it has some well defined general characteristics, which Fig. 2 will help to make clear. In point of fact, there appear to be several different types of sporadic

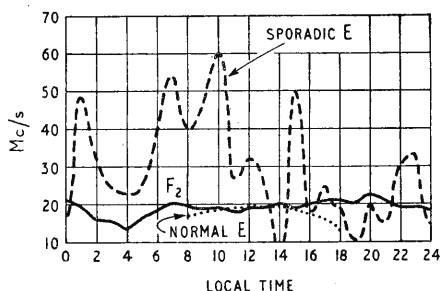

Fig. 1. Highest frequencies on which transmission could have been sustained during a June day at a mid-latitude northern hemisphere station.

E, even at a given location. There is certainly considerable difference between the types which predominate over different zones of the earth's surface, as is evidenced by, amongst other things, differences in the distribution with time of day and month of year. In the temperate zone, of which the location of Slough is typical, it is seen that the more intense sporadic E is largely a summer-time phenomenon, and, at that time, is chiefly prevalent during the day. In the auroral zones surrounding the geomagnetic poles, of which the Greenland station is representative, it is prevalent throughout the year, but is chiefly present at night, with a peak occurrence before midnight. At a station like Ibadan, near the geomagnetic equator, it is again prevalent throughout the year, but is largely confined to the daytime, with a peak occurrence around noon. In all zones it is often present for more than 30% of the time, and in the equatorial zone, during the daytime, has such a high degree of prevalence as to be practically a permanent feature of the daytime ionosphere. An ionospheric phenomenon such as this, capable of reflecting, at oblique incidence, frequencies higher than 25 Mc/s, and present over certain transmission paths for from 30% to over 90% of the time, is evidently of considerable importance, yet the

\*Research Dept., British Broadcasting Corporation

means necessary for taking account of its effects are at present inadequate.

The pronounced diurnal and seasonal features in its occurrence rate point to some sort of solar control, but, on the other hand, its generally sporadic nature would seem to indicate that it is not directly caused by the sun. In the auroral zones the sporadic E occurrence has a high degree of correlation with auroral and with geomagnetic activity, and both of these phenomena are almost certainly due to the action of solar corpuscles which, on arriving in the vicinity of the earth, are carried by its magnetic field towards the geomagnetic poles. So the auroral sporadic E may also be due to the effects of these corpuscles upon the atmospheric gas. But over the rest of the earth's surface there is no such correlation, and the origin of the "clouds" remains unknown. Various possibilities have been investigated by different workers: for example, that they are due to electric energy discharged into the E layer from thunder-clouds in the troposphere, that they are a by-product of the large electric currents which circulate in the ionosphere, that they are caused by meteors or by ionospheric winds. Some evidence has been presented in support of each of these possibilities, but none has been by any means proven.

**Night-time E Layer.** In general, the behaviour of the E layer closely resembles that of a Chapman layer, in which the maximum ionization is proportional to the square root of the cosine of the sun's zenithal angle. This follows from a consideration of the rate of ion production by the absorption of solar radiation by the gas molecules, and of the rate of recombination and attachment, which depends on the density conditions in the atmospheric gas.

At the height of the E layer the gas is relatively dense, and during the day the ionization increases from a low value at sunrise to reach a maximum around noon, and to fall again to a low value around sunset. After sunset it would be expected to continue falling rapidly, and shortly to disappear entirely;

but in point of fact, after falling rapidly for a time the rate of decay gradually diminishes until, sometime before sunrise the ionization appears to assume a constant value. The result is that the E layer has a low but definite ionization level throughout the night. It would appear, therefore, that there is a component in the E layer ionization which has a different recombination rate from that of the main body of the daytime ionization, and is due to a different cause, and that, after dark when the ionization due to the sun has disappeared, it is this which is maintained. Its origin is not, however, known, though it has, for many years, been thought to be due to the influx into the atmosphere of countless numbers of small meteors which, by reason of their high velocity, could ionize the gas atoms. It would seem that the ions produced in this way have a lower ionization potential and, therefore, a slower recombination rate, than those produced by the sun, and that, in this way, the ionization could be maintained. This night-time E-layer ionization is, at any rate, of considerable importance in communication, and particularly so in the new system which uses ionospheric scattering as the transmission mechanism, for this scattering occurs, both by day and night, in the ionization "turbulences" permanently existing in the E layer.

**Ionospheric Disturbances.** Long-distance communication via the ionosphere is subject to relatively frequent dislocation and interruption due to the effects of ionospheric disturbances. Yet little definite is known about the major kind of disturbance experienced; or, at least, insufficient is known about its cause and the mechanism of its production to be put to much practical use. If, for example, it were possible to tell within a day or two, or even within several hours, that such a disturbance were coming, extenuating measures could often be taken to prevent its worst effects.

Ionospheric disturbances are of two distinct kinds, though one kind is often associated with the other, and both have their origin in the sun. The

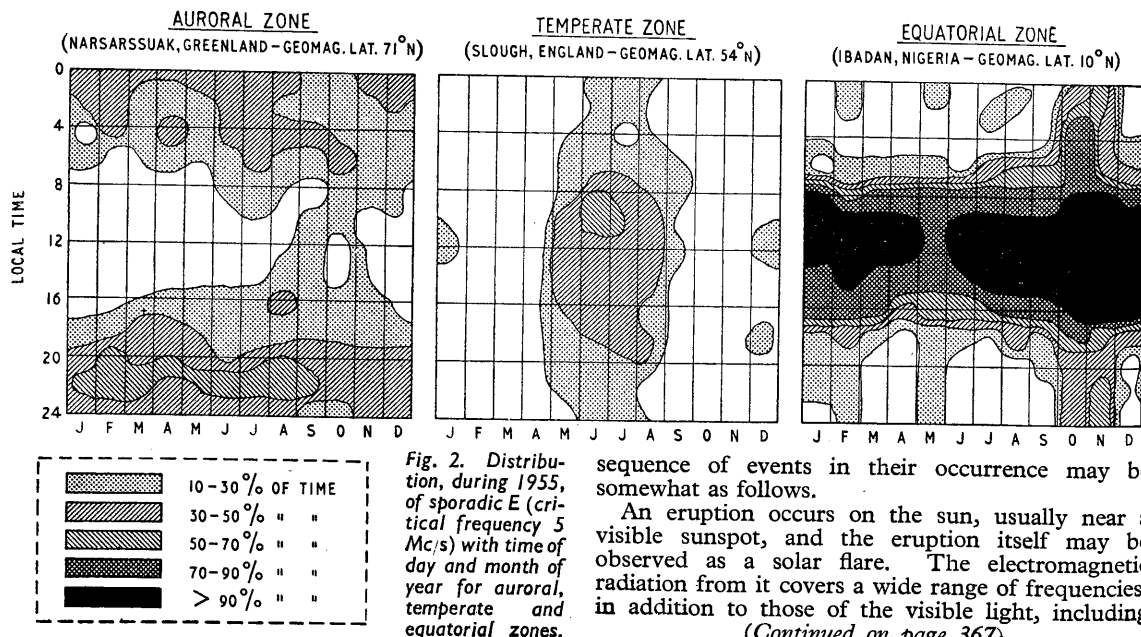

sequence of events in their occurrence may be somewhat as follows.

An eruption occurs on the sun, usually near a visible sunspot, and the eruption itself may be observed as a solar flare. The electromagnetic radiation from it covers a wide range of frequencies, in addition to those of the visible light, including

(Continued on page 367)



some far into the ultra-violet part of the spectrum. This latter penetrates into the earth's atmosphere to the level of the D layer, where it temporarily raises the ionization to a very high level. Radio waves travelling through this much enhanced ionized region, where, at the same time, there is a high density of neutral gas molecules, are subject to a greatly increased amount of absorption, due to the frequency of the electron/molecule collisions which they engender, and the resultant dissipation of their energy as heat. They therefore fail to reach the ground again, and communication is interrupted by what is called a "sudden ionospheric disturbance." The condition giving rise to this does not last long, however, for the burst of solar radiation usually dies down within a few minutes and, the recombination rate at the height of the D layer being high, the abnormal ionization within it usually disappears within an hour.

The sequence of events so far is pretty clear and well established, and, since the incidence of solar flares varies with the degree of sunspot activity we should expect that of the sudden ionospheric disturbances to correlate with sunspot activity also. Fig. 3 shows that, in general, there was, over the years 1947 to 1956, a good correlation between the Annual Sunspot Number and the annual number of sudden ionospheric disturbances.

But the latter is not the cause of the major interruptions to which h.f. communication is subject (since it is of such short duration). At the same time that the electromagnetic radiation from the flare occurs there is also emitted from the solar atmosphere, according to present ideas, a stream of corpuscles, which, in the form of a cone-shaped jet, has the disturbed solar region at its apex. Though the corpuscles constituting it possess individual charges the stream as a whole is neutral, and the corpuscles travel with a velocity of approximately 1,600 km/sec. The earth in its orbit encounters this stream (if it is emitted in such a direction that this is possible) about 26 hours later. As the corpuscles approach the earth they are affected by its magnetic field, and are swept towards the magnetic poles, so that the effects which they produce are more intense in zones surrounding the magnetic poles (the auroral regions) than elsewhere. These effects are of several kinds, viz.:

1. Disturbances in the earth's magnetic field (magnetic storms).
2. Disturbances in the ionosphere (ionospheric storms) consisting of abnormal decreases in the ionization level and in the height of the  $F_2$  layer, giving rise to deteriorations in h.f. radio propagation via that layer.
3. Displays of the polar aurorae and the setting up of abnormal earth currents.

All these phenomena, it should be noted, are different effects due to a common cause, the origin of which is a flare (or a sunspot region with which it is associated) on the sun. This type of ionospheric disturbance constitutes the major form of interruption to h.f. radio services, since it generally lasts for one or two days, and sometimes for as long as a fortnight.

The problem of forecasting these disturbances, which, given an up-to-date knowledge of the positions of sunspots and the occurrence of flares, might appear to be a simple one, is, in fact, very

difficult. This is because, whilst the sequence of events leading to them appears often to be as just described, in many other cases it appears not to be so. Many ionospheric storms occur without there being a flare or even a sunspot on which to pin their occurrence, and, on the other hand, many

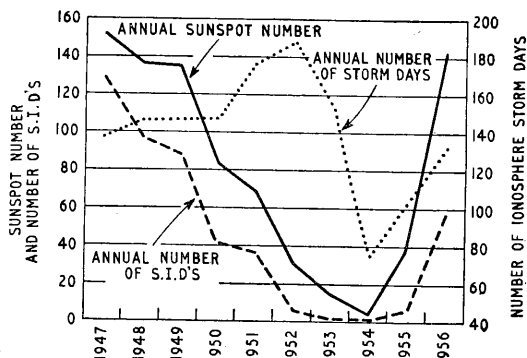

Fig. 3. Variation with sunspot activity in number of sudden ionospheric disturbances and in number of ionospheric storm days.

sunspots cross the solar disc without giving rise to any ionospheric disturbance. In short, the solar/terrestrial relations appertaining during the build-up and course of ionospheric storms are not yet properly understood, and it is well appreciated that the solar phenomena mentioned (and other solar data obtained by visual and radio means) do not correlate well with ionospheric disturbances.

In Fig. 3 the dotted curve is a plot of the annual number of days affected by ionospheric storms. In 1947, when sunspot activity was at a maximum, the number was high, having increased considerably from the previous sunspot minimum, and this was, no doubt, due to the connection of many storms with sunspots. But in 1951 when the sunspot activity was decreasing sharply, the number of storm days was increasing, and continued to increase in 1952. Only towards sunspot minimum in 1954 did the number of storm days decrease to a very low value. The 1952 peak in storm days corresponds with the well-known fact that, during the declining phase of sunspot activity, many storms of a type quite unconnected with sunspots occur. These storms show a very marked tendency to repeat themselves at 27-day intervals, and the mean period of the sun's synodic rotation, that is after allowing for the earth's motion in its orbit, is 27.3 days. Thus it is apparent that the cause of the storms is a certain region on the sun, which will always be "pointing" at the earth at approximately 27-day intervals. But these solar regions—called M regions—show no significant observable features to distinguish them from the rest of the visible disc, unless it be, as has occasionally been observed, a localized magnetic field, which may be a clue as to the special activity of the region.

Fig. 4 may be of interest in this connection. During 1953 the ionospheric storms associated with solar M regions were much in evidence, and 6th May marked the beginning of such a storm, as was evidenced by a deterioration in h.f. reception over transatlantic circuits. By calling this day and the next five days occurring at 27-day intervals from

t "zero days", and by taking the average reception quality for these circuits for the six periods about these zero days as shown, the full-line curve was obtained. This shows that there was a marked deterioration in reception during the periods following the days at 27-day intervals from 6th May. In 1955 the M-region storms had subsided and the storms which occurred may have been due to sunspots. A disturbance started on 25th May and, in the same manner as described, the dashed curve was plotted for the average of reception during six periods at 27-day intervals from it. The dotted curve is that giving the average reception during the periods around six zero days which were the days following the central meridian passage of six large sunspots during 1955, which occurred at May 21.3, June 16.4, Aug. 10.9, Oct. 7.0, Oct. 28.8 and Nov. 13.6. Neither the dashed nor the dotted curves show any significant reception variation connected with the zero days, the inference being that during 1955 there was neither a marked 27-day recurrence tendency in the ionospheric storms, nor any marked connection between the storms and the passage of the six sunspots across the sun's central meridian.

It is of interest to note that geophysicists are able to distinguish the *magnetic* storms associated with M regions from those due to other solar causes, such as sunspots. The latter are usually of the type with a sudden commencement (S-C type) as though they were produced by the sudden beginning of a corpuscular stream, whereas the recurring storms are more often of the non-S-C type, as though

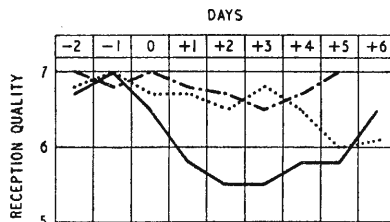

Fig. 4. Superposed epoch curves for quality of h.f. reception from eastern America based on the first day of the following events:

Full-line curve: Six 27-day intervals from 6th May, 1953.  
Chain dot curve: Six 27-day intervals from 25th May, 1955.  
Dotted curve: Day following CMP of six large sunspots 1955.

Reception quality: 7 = good; 6 = fair to good; 5 = fair.

produced by a persistent and long-lived stream. It has not, however, been possible to distinguish different types of *ionospheric* storms in this way, except by reference to their magnetic counterparts.

It will be gathered from the above—and that is the point of this discussion—that much remains to be learnt about this interesting subject, and the solar-terrestrial relations require to be better understood, before much practical use can be made of the data.

These, then, are three ionospheric problems affecting radio communications. And there remain, of course, many others. The IGY world-wide data should, when analysed and co-ordinated, throw some helpful light upon some of them.

## French Air Show

New Electronic Developments at the 22nd Salon International de l'Aeronautique

VISITORS to aeronautical exhibitions are now accustomed to a large proportion of the apparatus shown being of an electronic nature and for new systems and devices to appear each year. However, although electronics are now more important than ever for the successful and safe operation of aircraft, a period of stabilization is being reached when the accent is more on the improvement of apparatus and its reliability than on new devices.

This position was confirmed at the 22nd Salon International de l'Aeronautique held at Le Bourget aerodrome near Paris recently, where aeronautical electronic equipment from a number of countries was shown. Specifications of apparatus were more comprehensive than hitherto, and guarantees of satisfactory performance at altitudes in excess of the existing world's record were given for some of the apparatus exhibited. As an example, for such a simple device as a 75-Mc/s marker receiver aerial for use with radio ranges and instrument landing systems (ILS), Collins supply curves of the v.s.w.r. over a temperature range between  $-60^{\circ}\text{C}$  and

$+60^{\circ}\text{C}$  together with a polar diagram of reception. S.T.C. quote the aerodynamic drag of their Bent Sleeve v.h.f. aerial as 6.25 lb at 400 m.p.h. The operating life of the American DF301 airborne DF equipment is quoted both in terms of stability before readjustment of pre-set controls is required and in terms of minimum operational hours before removal for a bench test is needed, these characteristics being equated to the *g* forces, vibration and acoustic noise of very high-speed aircraft.

An examination of the latest airborne radio equipment shows that much thought is being given to rapid servicing facilities, not only for military apparatus but also for that used in civilian aircraft. If it is borne in mind that the Boeing Type 707 jet air transport is designed to carry 55,000 passengers per year across the Atlantic (equivalent to the number carried by a large ocean-going liner) the small amount of time which this aircraft can be on the ground for servicing will be appreciated. The introduction of this aircraft into regular service in the very near future will probably bring about drastic

changes in aeronautical radio and radar technique, as well as in equipment design, as it will fly at twice the altitude and twice the speed of existing airliners. As these aircraft will be entering control zones where aircraft of much slower speed are flying and, due to their high speed, will only be visible for a relatively short period on surveillance radars, their early identification will be essential. At present the procedure for identification is for aircraft to carry out a turn while under observation from the radar; such a manoeuvre would of course be unsuitable for the fast jet aircraft and to meet the new requirement Collins have introduced their Type 621A Air Traffic Control Interrogator-Transponder. With this system a directional aerial and associated transmitter and receiver are installed at the ground radar site and the aerial rotation is synchronized with that of the surveillance radar. The ground station sends out a pair of spaced pulses on a frequency of 1,030 Mc/s which is received in the aircraft. The reply is sent back from the aircraft on a frequency of 1,090 Mc/s and consists of a group of 2 to 8 pulses, each spaced by 2.9  $\mu$ sec.

Exhibits at the Paris Salon showed that transistors are gradually finding their way into aircraft equipment where they are making an important contribution to the reduction in the size of units. A typical fully transistorized item of airborne equipment was shown by Collins in the form of their "Interphone" which measures 12  $\frac{3}{16}$  in deep, 2  $\frac{1}{4}$  in wide and 7  $\frac{3}{8}$  in high and weighs about 5 lb.

For medium frequency operation transistors in their present state of development work satisfactorily and it is therefore logical that a fully transistorized radio compass should be produced for airborne use. Lear Incorporated appear to be the first manufacturers to introduce such an instrument; it is their model ADF100. A total of 23 transistors is used with the Type 2N247 in the radio frequency stages, the Type 2N139 in the i.f. amplifier and a 2N158 supplying the AF output of 150 mW. In this receiver 80% of the circuits are of etched type and of standardized (modular) construction with plug-in units to facilitate servicing. The performance of the ADF100 is equal to that of a conventional instrument, the full band from 1,705 to 190 kc/s being covered, with a sensitivity varying between 10 and 20 microvolts for a 50-milliwatt output. The compass bearing accuracy and sensitivity are  $\pm 2^\circ$  with a signal of 50 microvolts per metre. The total weight

of the equipment is under 20 lb and its current drain does not exceed 0.75 A.

Doubtless transistors will find increasing uses in aircraft, not only for radio and radar units but also for instrumentation and servo mechanisms. S.T.C. exhibited a device in this latter category, the type A1205 Transistorized Aircraft Catastrophic Warning Unit, designed to alert a pilot of an aircraft acoustically to an emergency. Normally this is done visually by warning lights on the dashboard, which illuminate in similar emergency circumstances. The A1205 Unit is connected into the circuit which normally operates these lights and it generates a sound closely resembling that of an alarm bell.

At the last Paris Salon in 1955, one prototype u.h.f. airborne equipment was shown for the first time publicly in Europe. This year one American and three French made airborne u.h.f. equipments were on view, in addition to a comprehensive range of u.h.f. ground station transmitters and receivers. The u.h.f. band lying between 225 and 399.9 Mc/s will be used exclusively by military aircraft eventually, but at present a large number of American aircraft operating in Europe are using this band for communications.

### More Channels

Operational needs with modern aircraft engaged on military duties are evidently very exacting, since, whereas in the 1939-45 war a total of 12 v.h.f. frequencies sufficed for most operational needs, today a total of 1,750 channels is required, any of which can be selected by the pilot, and 20 are needed for instant use. In addition, a guard-frequency receiver, entirely separate from the main receiver, is essential for command purposes. Such a specification has made it necessary to develop most advanced techniques in circuits and construction of sub-miniature units. In the American u.h.f. transmitter-receiver ARC52, pressurization is used to prevent flash-over at maximum altitudes of working, which are in the neighbourhood of 70,000ft. In all of the airborne equipments exhibited, printed wiring, modular construction and sub-miniature components are used. Pencil and sealed-disc valves are fitted in the r.f. circuits and cavity tuning is included in receiver input and transmitter output circuits. The table shows the main characteristics of these exhibits.



Type FR308 life-jacket beacon "transceiver" for airmen forced down in the sea.

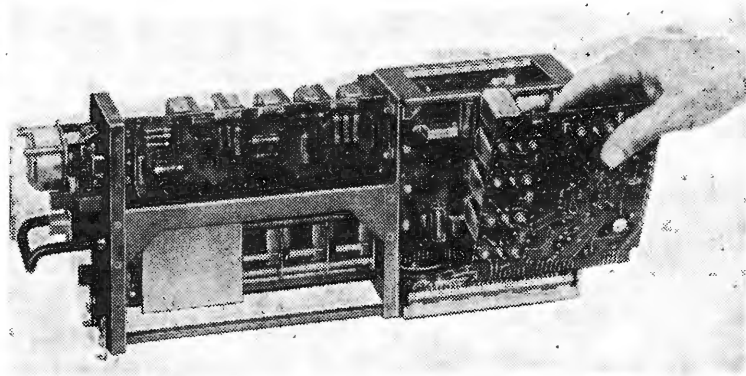

Lear transistorized radio compass, Type ADF100.

Collins Type 621A Air Traffic Control Transponder for aircraft identification on ground surveillance radars.

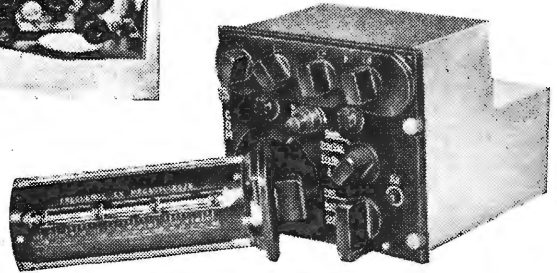
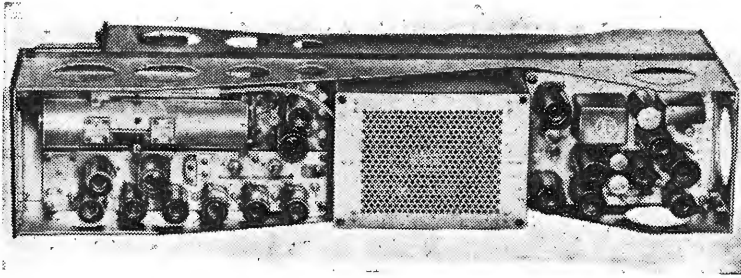

Control box of S.F.R. Type SU205 u.h.f. aircraft equipment.

In the u.h.f. equipments at the Salon, all the control boxes are provided with a 20-frequency selector switch and also with a tuning arrangement consisting of four dials with which the hundreds, tens, units and tenths of megacycles are selected. The pre-setting of the 20 frequencies is very much simpler than with previous multi-channel apparatus, such as Service v.h.f. types, and is all done at the control box. A switch turret is removed and the contacts corresponding to each channel are adjusted to the frequency required by setting them up against a calibrated scale engraved on the turret.

To provide the 1,750 channels required, a master oscillator unit is used in current designs. Its output is multiplied and amplified directly up to the frequencies required for the first local oscillator in

tion on a normal radio compass dial display and has a bearing accuracy under service conditions of  $\pm 5^\circ$ , and an "indicator hunt" of one degree on level flight. It is designed to operate to altitudes of 70,000 ft and between temperature limits of  $-55^\circ\text{C}$  and  $+100^\circ\text{C}$ .

The DF aerial, which in the form of a loop flush-mounted in the aircraft fuselage, receives the signal and a mechanically-operated switch reverses the polar diagram at a frequency of 100 c/s. This switching has the effect of modulating the signal with a square wave, the amplitude and phase of which varies with the angle of the aerial. The modulated signal is fed to the receiver where it is amplified and the r.f. component is removed. The 100 c/s square wave is then passed to a phase detector which in turn feeds a saturable transformer controlling the aerial drive motor, which can turn it in either direction, and which will find the null position when the input level to the receiver is constant and there is zero error signal. A synchronous transmitter associated with the aerial motor feeds the necessary voltage to the pilot's bearing indicator.

A useful outcome of the introduction of the u.h.f. radio compass is an improvement in the Air Sea Rescue service. It is now possible to home on to a u.h.f. signal and as a consequence of this development very small transmitters, such as the British Ultra "Sarah" and the Burndep "Talbe," have been designed which can be carried in the "Mae West" life jackets worn by Service pilots and which can be used to enable search aircraft to locate "ditched" airmen. A further example of these life jacket equipments is the Type FR308 made by Telecommunications Radioelectriques et Telephoniques. This model gives a tone-modulated transmission on the u.h.f. channel of 243 Mc/s, the international distress frequency, and also has facilities for the transmission of speech and for reception of u.h.f. signals. The speech sending and receiving facilities have been included for the practical reason that it is often easier for a "ditched" airman to see the search aircraft against a background of sky than for the search aircrew to see the man in the water against a background of sea, and it has been found that if the "ditched" airman can communicate with the aircraft he can often guide the aircraft to his position.

Make	Channels	Stability	Power output (watts)	Max. working altitude ( $\times 1,000\text{ft.}$ )	No. of valves	Recvr. Sens. ( $\mu\text{V}$ )	No. of crystals	Weight
S.A.R.A.M. Type 7-50	20	$\pm 10$ kc/s	15	65	—	5	—	25 kg
S.F.R. Type SU205	20	"	10	—	65	5	18	25 kg
Derveaux Type 157B (pressurized)	20	"	9	—	—	—	21	25 kg
Collins Type ARC52 (pressurized)	19	"	20	70	43	5	36	23 kg

the double superheterodyne receiver. At the v.h.f. stage of multiplication some output is drawn for the transmitter and it is applied to a transposition stage where it is heterodyned with a crystal-controlled oscillator. This arrangement enables the same fundamental frequency to be used both for transmission and for the receiver local oscillator. The frequency of the master oscillator is held stable by a frequency-controlled stage consisting of a number of crystal oscillators operating into a phase discriminator. The output from this stage is used to control a reactor valve working directly on the master oscillator and also on the motor driving the variable tuning controls of the multiplier, amplifier and output stages associated with the transmitter; and the multiplier, amplifier and input stages of the receiver.

An interesting accessory to the u.h.f. airborne equipment, the Collins DF301, was shown for the first time in Europe. It presents bearing informa-

# LETTERS TO THE EDITOR

The Editor does not necessarily endorse the opinions expressed by his correspondents

## Gramophone Reproduction

IN your June issue Mr. D. A. Barlow refers to my article in *Electronic Engineering* for May 1950 and he suggests that the three components of load on the walls of a gramophone record groove, the lateral stiffness, the lateral inertia and the vertical stiffness, do not add but that they are largely complementary.

Consider Fig. 1 where a plan of a groove is shown cut with a pulse of long wavelength and large amplitude, and superimposed on this is a short wavelength modulation. This type of cut often happens with loud music passages. The force acting on the needle due to the long wavelength pulse is equal to the product of the horizontal stiffness of the movement and the amplitude of the pulse. The force acting on the needle due to the short wavelength modulation is equal to the product of the horizontal inertia of the movement and the acceleration of the needle; the latter should not be greater than that which will be obtained when the minimum radius of curvature of the modulation is approximately equal to that of the radius of the needle tip.

Now in position A, Fig. 1, it is true to say that the inertial force acts on one groove wall and the stiffness force on the other. But in position B this is not true and the two forces add. Thus the tracking weight must be sufficient to counteract these added forces.

Fig. 2 shows a plan of a groove and the consequent vertical motion of the needle due to the pinch effect. Without modulation of the groove the needle remains in its lowest position such as at C. If the needle is pulsed vertically then no extra tracking weight is required to hold the needle down, in fact the force between the needle and the groove is increased due to the action of the vertical stiffness of the cantilever. But suppose we have a modulation giving a large-pinch effect amplitude continuing for

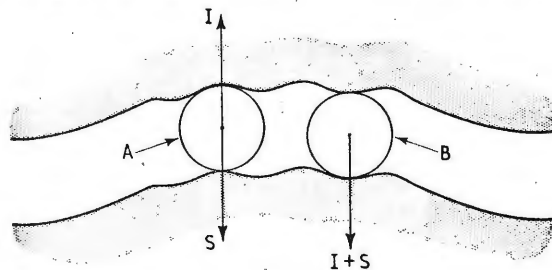

Fig. 1

a time longer than half the inverse of the low-frequency vertical resonance (and this happens often on records), then the pickup head will be raised and the needle will take up a mean position such as that shown by the line D and when the needle drops to a point such as E the vertical force on the needle will have been reduced by the product of the vertical stiffness of the cantilever and the maximum vertical amplitude (DE). This amplitude is not likely to be more than one-fifth of that I originally suggested, this later figure assumes a maximum velocity of cut of 20 cm/sec at 70 r.p.m. Unfortunately this reduction of vertical force occurs at a point when the force due to lateral stiffness and inertia is a maximum so that it is essential that the tracking weight counteract the sum of the three forces considered. Incidentally the vertical inertia may be ignored, not because it is unimportant but because its contribution to the tracking weight is small in the design of pickup considered. As the tracking weight is greater than the author suggests,

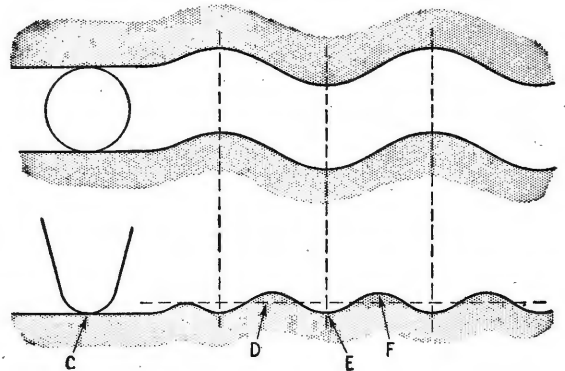

Fig. 2

the static load on the groove wall will be increased. Moreover the load will be greater still at points such as F, especially when there are only a few pulses of vertical motion. This makes the design of the pickup suggested even more difficult, perhaps impossible.

Be that as it may it is heartening to see yet one more article written by someone striving for better quality from gramophone records. The worst fault of present records is their radius or acceleration overmodulation. The recording companies are like a railway company who slowly improve their service from the "Rocket" days to the present time—the trains travel faster, are more comfortable, their meals become eatable—but they do not cure the unfortunate habit of laying their tracks with sharp corners so that the trains keep coming of the rails!

I maintain that some of the records cut before the war, e.g.—the Weingartner Beethoven Symphonies, are superior to most of those of the present day. On these old records there was a recording high-frequency cut-off at about 6,000 c/s and the modulation depth was lower than that of to-day, consequently there was no radius overmodulation. I would like better quality even at the expense of the high-frequency boost on recording which would give a noisier playback, or at the expense of the frequency response on recording which would give a consequent narrow playback frequency response, and then nobody could ask me to enthuse over the sound of pennies dropping or the spurious noises of orchestral instruments. However, as I grow older I tend towards the philosophy suggested in your June editorial and treat distortions as I do coughs and splutters in a live performance of music—something I do not like but which I must ignore.

Aldershot.

E. S. MALLETT.

I FEEL that I should comment on Mr. D. A. Barlow's remark in the May issue that "it used to be the practice of record companies to monitor the original wax or lacquer disc before plating to make the master."

It was toward the end of 1922 that I joined J. E. Hough, Ltd., to organise the Radio Research Dept. That company (which later became Edison Bell, Ltd.) was then making Edison Bell records, gramophones, and also mouldings for the radio trade, and wished to make components and sets.

At that time, horn recording was used in the studio. That is, one or more horns were coupled to a special soundbox driving the sapphire cutting stylus directly. I had not been with the firm long before it occurred

to me that with a microphone, amplifiers and some cutting device actuated electrically (as the B.B.C. did its carrier), it should be possible to record a better representation of the original sounds.

The suggestion was well received and I was allowed to make experiments on the subject when my radio work permitted. So by 1924 I was in and out of the studio quite often and had first-hand knowledge of their methods.

By 1926, the new system which used a slack diaphragm condenser microphone and a moving coil cutter was being operated, and in 1927 I spent six months with duplicate equipment on a recording expedition to Zagreb, Yugoslavia, where I recorded over 600 titles. Other foreign expeditions followed and my last trip for Edison Bell was in 1933 to Scotland where we were recording for the Beltona label. Edison Bell ceased operations in the slump that year. I can therefore claim to have an intimate knowledge of recording as practised at Edison Bell in the decade ending 1933.

During the whole of that period master waxes were never played (monitored) prior to processing. Such an idea would have been condemned instantly by everyone connected with the work, for the wax used for making masters was very soft and would most certainly have been damaged most seriously.

The idea that waxes were monitored may have arisen from the fact that certain waxes were regularly played back. The waxes used for that purpose however were of a harder texture, were called test waxes and made a hissing noise while being cut. When the music had been selected, cut to fit into the time, the musicians rehearsed etc., the usual thing was to make a trial recording on to a test wax. This was then immediately played back to the artists on a special machine.

When I was recording, I allowed any master waxes spoiled by technical or musical faults to cool off and played them privately after the session before releasing them for re-shaving. This gave me a better check on the equipment, for the better wax with its silent background was more revealing than the noisy test wax.

Needless to say, in due time pickups and loudspeakers were used for the playback system, but no matter how delicate the pickup might be, satisfactory masters were never played prior to processing.

Lacquer discs are a subsequent development and I do not know what other companies did when using these. However, I would expect that the tradition that

the master wax *must* be left intact would be carried forward indefinitely in professional circles.

Toronto.

P. G. A. H. VOIGT.

## Mobile Radio 25-kc/s Channelling Trials

THE report in your June issue (p. 256) regarding the Post Office trials of 25-kc/s mobile equipment, is not quite accurate. Trials, as recommended by the Mobile Radio Committee in fact commenced in May of this year, and are now under way using three adjacent channels in the low band and operating in the London area. They are being carried out with standard "Ranger" equipment manufactured by our Company.

The target 25-kc/s channelling specification referred to in the Committee's report, has been established with manufacturers' agreement, and is based on the same principles and requires the same degree of channel isolation laid down in the 50-kc/s specification. The Pye equipment has recently been approved to this 25-kc/s specification and some 500 "Ranger" mobiles meeting it are now in constant use in this country alone.

Our Company policy is to recommend 25-kc/s channelling equipment for all standard mobile schemes in this country even though the channels are at present spaced at 50 kc/s. At the same time all "Ranger series" equipment is readily convertible from one standard to another. In these circumstances users will have little difficulty in deciding which specification will give them maximum technical life and the minimum of channel sharing in the longer term.

Cambridge.

J. R. HUMPHREYS,

Pye Telecommunications, Ltd.

## Services Charges

MR. MAYER, in his review of colour TV in the U.S.A., refers to the "lively imagination" of those who report that an engineer is required per set installed. Your contributor has made use of a good deal of the same thing in quoting £17 as the comprehensive service charge in this country for a black-and-white 17-in receiver.

My own company offers these facilities for £7 per annum; the dearest quotation I can trace is only £9.

It is to be hoped that his conclusions are not coloured by any other imaginative figures of conditions in the U.K.

MAURICE SOKEL,

Edgware.

JMS Radio and Television, Ltd.

## SHORT-WAVE CONDITIONS Prediction for August

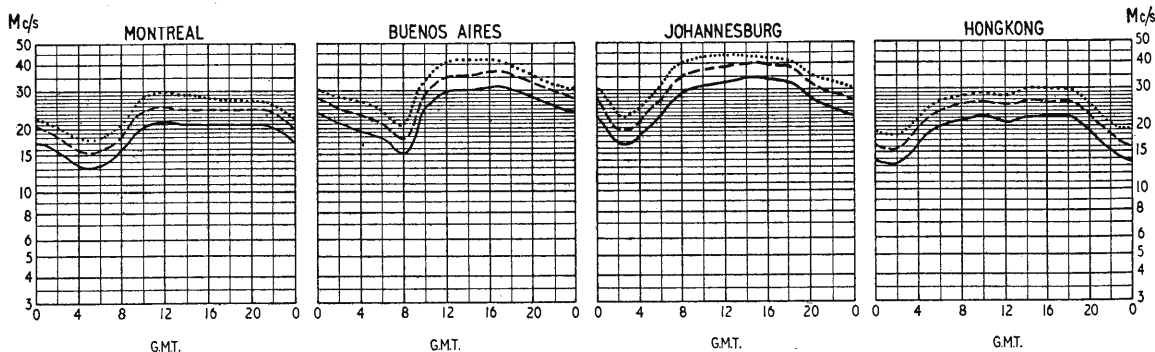

THE full curves given here indicate the highest frequencies likely to be usable at any time of the day or night for reliable communications over four long-distance paths from this country during August.

Broken-line curves give the highest frequencies that will sustain a partial service throughout the same period.

- ..... FREQUENCY BELOW WHICH COMMUNICATION SHOULD BE POSSIBLE FOR 25% OF THE TOTAL TIME
- - - - PREDICTED AVERAGE MAXIMUM USABLE FREQUENCY
- FREQUENCY BELOW WHICH COMMUNICATION SHOULD BE POSSIBLE ON ALL UNDISTURBED DAYS



# Multi-Valve Cathode Follower Circuits

## 2—PRACTICAL DESIGN CONSIDERATIONS

By J. G. THOMASON, B.Sc.

(Concluded from p. 313 of the previous issue)

**T**HE various cathode followers described so far may be classed as single-stage circuits since only one valve is directly providing loop gain, other valves (or neon tubes) merely improving the gain and signal-handling capacity of this valve.

**Two-stage Cathode Follower.**—Where a greater increase in performance is required, it is logical to try to add an extra stage to the cathode follower in order to secure a larger loop gain and feedback factor. It is not a straightforward matter of adding a stage to the forward circuit as in the conventional negative feedback system, since the negative feedback in the cathode follower is inherent with the configuration and not an external connection imposed by the designer. The only way in which negative feedback may be applied to two cascaded plain amplifying stages is by making a connection from the anode of the second valve to the cathode of the first valve. The output is taken from the anode of the second valve. Both valves now give gain in the forward circuit, which is superior to the use of local feedback in individual stages.

For operation at frequencies down to zero frequency, however, an anode output terminal is often inconvenient because of the inherent large positive quiescent voltage (say, +150 V). A simple resistive d.c. coupling network connected to a negative line can be used to obtain zero quiescent output voltage, but the price paid is a higher output impedance.

For this reason it is attractive to add an extra stage in cascade with the basic cathode follower and to make a shunt feedback connection from the

cathode follower output to the grid of the first valve. A simple example of such a circuit is shown in Fig. 8, using the 12AT7 double triode. The gain of the outer negative feedback loop, via the two 1 MΩ resistors is about 12 and this reduces the output impedance of the overall circuit to about 16 ohms compared with the 200 ohms of the second triode as a simple cathode follower. The circuit will function as a feedback amplifier if the ratio of the feedback resistor (R<sub>2</sub>) to feed-in resistor (R<sub>1</sub>) values is increased above the figure of unity used in the circuit in Fig. 8. It may be shown that in any shunt feedback system the overall gain G is given by:

$$G = - \frac{R_2}{R_1} \cdot \frac{L}{1+L} \dots \dots \dots (9)$$

where R<sub>1</sub> and R<sub>2</sub> are the values of the feed-in and feed-back resistors respectively and L is the loop gain of the system. The minus sign indicates a phase reversal. By careful adjustment of R<sub>1</sub> and R<sub>2</sub> it is possible to make the circuit give an overall gain of exactly unity if required. This condition would only hold for a certain value of L, however, i.e.

$$R_2 = R_1 (1 + 1/L) \dots \dots \dots (10)$$

The quiescent output voltage of the circuit (earthed input terminal) will be positive and equal to (R<sub>1</sub> + R<sub>2</sub>)/R<sub>1</sub> times the grid bias on the left-hand triode e.g. approximately +3.5 V for the circuit values shown, corresponding to a grid-cathode voltage of -1.75 V in the left-hand valve.

The circuit is a multiple-loop negative feedback system, but as the inner loop (i.e. the output stage cathode follower on its own) is stable and the outer loop remains stable whether the inner loop is operative or not, it is quite permissible to analyse the system disregarding the fact that the cathode follower stage derives its characteristics from an inherent feedback connection.

In this circuit, however, the input impedance is no longer determined by the inherent series feedback of the cathode follower but is controlled by the overall shunt feedback, giving a low input impedance (equal to R<sub>1</sub>, approx.) which may limit the applications of the circuit as a buffer stage. Where it is desired to retain the high input impedance the added triode amplifier stage in Fig. 8 may conveniently be replaced by a long-tailed pair as shown in Fig. 9. The long-tailed pair (or "difference amplifier") now performs the dual function of mixing, i.e. subtracting the input and feed-back voltages, and also providing extra gain for the external negative feedback loop. The long-tailed pair gives only half the gain of the single stage, but this loss is conveniently offset by changing to a low current high-μ valve such as the 12AX7, since one half is no longer

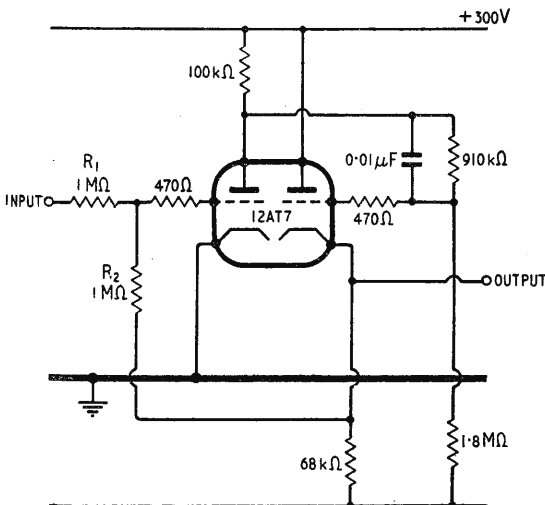

Fig. 8. Two-stage shunt feedback cathode follower.

required to function as an output stage. The loss of loop gain in the feed-back and feed-in resistors of Fig. 8 is eliminated and the circuit shown has a gain of 19 round the external loop. The feedback factor is thus 20, giving an output impedance of 10 ohms compared with the 200 ohms of the cathode-follower stage alone. Note that a control is provided for arranging to feed back only a fraction of the output voltage so that the finite feedback factor may be allowed for an exactly unity gain obtained.

A further useful feature of the circuit shown in Fig. 9 is its ability to provide a quiescent output voltage of zero. This condition is set up when the long-tailed pair is adjusted so that the two grid voltages must be equal for the current partition to be such that the anode voltage of the right-hand valve sits at the design value. The "balance" control shown enables this condition to be found since, for a given current partition, it varies the anode voltage of the left-hand valve and therefore its grid base with respect to the right-hand valve. This circuit is particularly useful where a simple buffer circuit is required which introduces neither attenuation nor d.c. shift. The long-tailed pair also assists in reducing drift due to heater fluctuations and cathode ageing, giving an improvement factor of about 10 compared with the single-ended circuits.

There are no stability problems with the multi-stage feedback circuits shown in Figs. 8 and 9. In the circuit of Fig. 8, there are two lags of almost equal time constant, at the amplifier triode anode and at its grid, a situation which can give a dangerously large phase lag when considering also the third small time constant lag at the cathode-follower cathode. The low value of loop gain in the circuit given, however, precludes the danger of oscillation and where a valve of higher gain is used, the lag at the amplifier stage grid could be removed by shunting  $R_2$  with a 22 pF capacitor. The frequency response of the overall system is restored by similarly bypassing  $R_1$  with the same value of capacitance. This stabilization method, of course, places an extra 22 pF capacitive load on the signal source.

The circuit of Fig. 9 is inherently more stable since there are only two lags, the lag of large time constant at the right-hand anode of the long-tailed pair (about  $2\mu\text{sec}$ ) and the lag of small time constant at the cathode-follower stage cathode (about  $0.005\mu\text{sec}$ ).

In both circuits the capacitor in the d.c. intervalve coupling network prevents the formation of an extra lag at the cathode-follower grid, at the expense of increasing the time constant of the lag at the preceding anode. It is, of course, standard practice in negative feedback work to reduce the number of lags to the absolute minimum in the interests of stability.

**Two Examples of Complex Multi-stage Cathode Follower Circuits.**—When two amplifying stages are added in cascade with the basic cathode follower

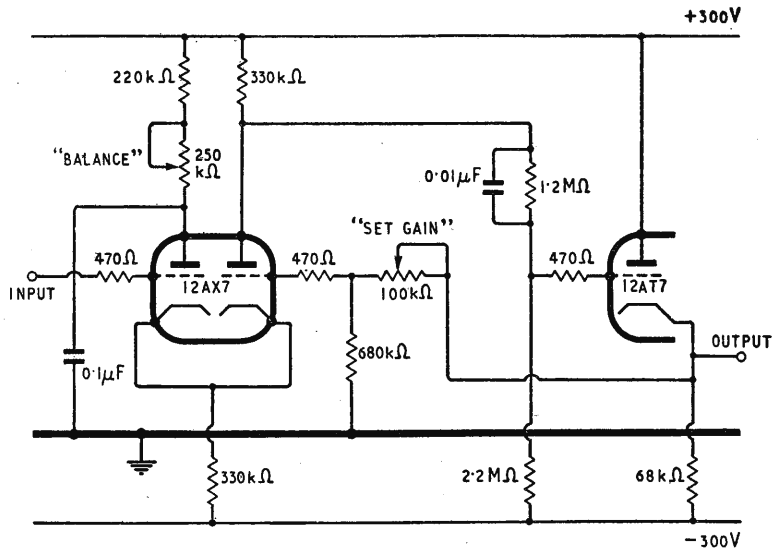

Fig. 9. Two-stage cathode follower with difference amplifier.

the individual phase reversals of the extra stages add to give no total phase reversal, and it is therefore possible to revert to cathode feedback in the first stage, as in the simple cathode follower or the two-stage a.c. circuit mentioned earlier. A simple version of this three-stage cathode follower is shown in Fig. 10, using a double triode to provide the two extra stages. Series feedback is provided by injecting almost the entire voltage from the output cathode follower into the input valve cathode. With the component values shown, the measured loop gain at 500 c/s is about 4000. At zero frequency the gain falls to about 700 due to losses in the inter-stage couplings and the local feedback caused by the cathode resistor of the input valve.

The input stage and second stage are both connected as low-consumption voltage amplifier stages, using the high- $\mu$  triode, 12AX7. The output stage is conveniently made a simple cathode-follower using a single triode, a pentode or a double triode. The output cathode-follower load is divided so that a fraction of the output may be fed back, to secure an overall gain of exactly unity for operation at very low frequencies. The quiescent output voltage may be adjusted to be zero by arranging cathode bias on the first stage as shown. With the input earthed, the 1.5 kΩ resistor and 1 kΩ potentiometer combination may be set so that their voltage drop is equal to the 1.6 volts grid bias required by the input stage plus the 3.1 volt drop across the 270-ohm resistor. The 100  $\mu\text{F}$  cathode decoupling capacitor is effective for frequencies down to about 1 c/s, and at z.f. the stage gain is reduced to one-third approximately by the presence of this cathode biasing resistance.

The feedback loop is not inherently stable since there are three lags, at each of the amplifying stage anodes and at the output cathode follower cathode. Allowing 130 pF at the first valve anode, including anode-earth capacitance (0.4 pF), Miller effect at the grid of the second valve (110 pF), and wiring capacitance (20 pF), would give a lag of time constant:  $(65\text{ k}\Omega)(130\text{ pF}) = 8.5\mu\text{sec}$ . (approx.)

The lag at the second valve anode is formed by,  
(Continued on page 375)

say 20 pF capacitance to earth, giving a time constant:—

$$(65 \text{ k}\Omega) (20 \text{ pF}) = 1.3 \text{ }\mu\text{sec. (approx.)}$$

In both cases the anode-earth resistance is calculated as the value of the load resistance in parallel with the valve differential anode resistance (80 k $\Omega$ ).

The time constant of the lag at the output is calculated from the differential resistance at the output stage cathode (100 ohms) and say 30 pF load capacitance, giving:—

$$(100 \text{ ohms}) (30 \text{ pF}) = 0.003 \text{ }\mu\text{sec. (approx.)}$$

The phase advance provided by the cathode decoupling of the input stage and the two inter-stage couplings is arranged to be distributed over the band 1 c/s to 200 c/s (approx.) and does not affect the h.f. stability of the loop. The phase advance contributed by the 100 pF capacitor shunting the 270-ohm resistor is negligible at any frequency. The simple theory of the stability of the three-lag feedback loop indicates that with these three values of time constant, a h.f. loop gain of 2,940 (approx.) or higher will make the loop unstable. This critical value of loop gain  $L$  is calculated from the formula:—

$$L = (m + n) \left(1 + \frac{1}{m}\right) \left(1 + \frac{1}{n}\right)$$

where  $m$  and  $n$  are the respective ratios of the two larger time constants to the smallest one. In this design, stability has been achieved by the common method of increasing the largest time constant, in this case increasing the time constant of the lag at the input stage anode from 8.5  $\mu$ sec. to 333  $\mu$ sec (approx.) using the 0.005- $\mu$ F capacitor shown shunting the anode load resistor.

The critical value of loop gain is increased to about 110,000, giving a generous gain margin and adequate bandwidth for most applications where circuitry with triode amplifying stages is considered appropriate. The phase margin is 90° over most of the cut-off interval. Low frequency stability is assured by the absence of a.c. couplings and the staggering of the phase-advance time constants. The output stage shown in Fig. 10 operates at 11.6 mA quiescent current and the overall output impedance is about 0.13 ohm at z.f., falling to about 0.025 ohm at 500 c/s.

The circuit shown in Fig. 10 has a very large loop gain at mid-band frequencies and if a smaller fraction of the output voltage is fed back, some of the loop gain may be conceded in exchange for overall gain. The reduced feedback is achieved simply by altering the ratio of the resistors forming the output stage cathode load, at the same time adjusting the d.c. conditions, or else changing to a.c. couplings. In this form it is usual to replace the triode amplifying stages by pentodes, when the circuit

becomes the familiar "ring-of-three" fast pulse-counting amplifier commonly used in nuclear physics.

It is important to note that in the circuit of Fig. 10, the fraction of the output voltage which must be fed back in order to secure unity overall gain has not the value (loop gain)/(1+loop gain) which was used in the shunt feedback circuits (Fig. 8). The cathode injection method of subtracting the input and feed-back voltages does not give a perfect subtraction of the grid and cathode voltages since for a fixed anode current in the first stage, the difference between the grid and cathode voltages varies with the working anode-cathode voltage (screen-cathode voltage for a pentode). The ratio is simply the amplification factor  $\mu$  of the first valve and it is seen that even if the stages following the input valve gave infinite gain, it would still be necessary to feed back a fraction  $\mu/(1+\mu)$  of the output voltage in order to secure an overall gain of unity. In the circuit shown in Fig. 10, the  $\mu$  of the first valve is 100 and with a loop gain of 700 at z.f., it is necessary to feed back about 1/90 of the output voltage to obtain unity overall gain at low frequencies and z.f. The overall gain stability must therefore be controlled largely by the characteristics of the first valve, however high the loop gain. Several ingenious refinements are available to remove this weakness of the circuit, the simplest being to use a pentode input stage with a.c. bootstrap screen decoupling, similar to the circuit in Fig. 6 in the first part of this article.

Imperfect signal subtraction caused by the changing valve operating conditions also occurs in the long-tailed pair. In the circuit of Fig. 9, for example, variations in the "tail" current of the double triode necessitates feeding back an appreciably larger voltage to the right-hand grid than the fraction (loop gain)/(1+loop gain), to give unity overall gain. For example, suppose the "balance" control in Fig. 9 has been adjusted so that with zero input

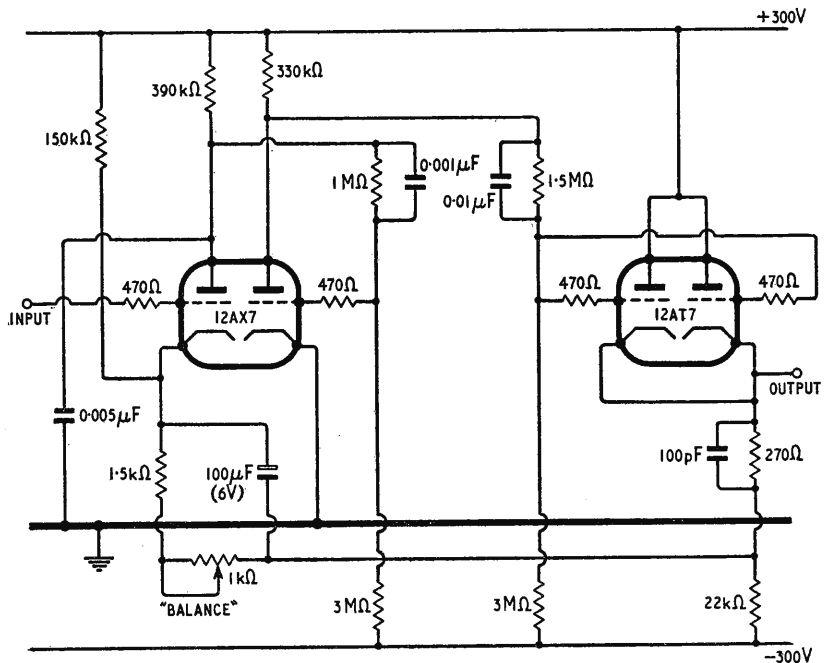

Fig. 10. Three-stage cathode follower.

voltage the two grid voltages need to be equal to produce a given voltage at the right-hand anode (say +150 V, which would give zero output voltage from the output cathode follower). If the left-hand grid voltage is now made, say +50 V, the +150 V at the right-hand anode will only be restored if the right-hand grid voltage is made slightly lower than +50 V. The common cathode voltage has increased, also by about 50 V, turning on an extra 0.15 mA in the 330 kΩ common cathode "tail" resistor. All this extra current, however, must flow into the left-hand triode since the current in the right-hand triode is constant, by virtue of its assumed fixed anode voltage. It is seen, therefore, that the grid of the left-hand valve will need to become more

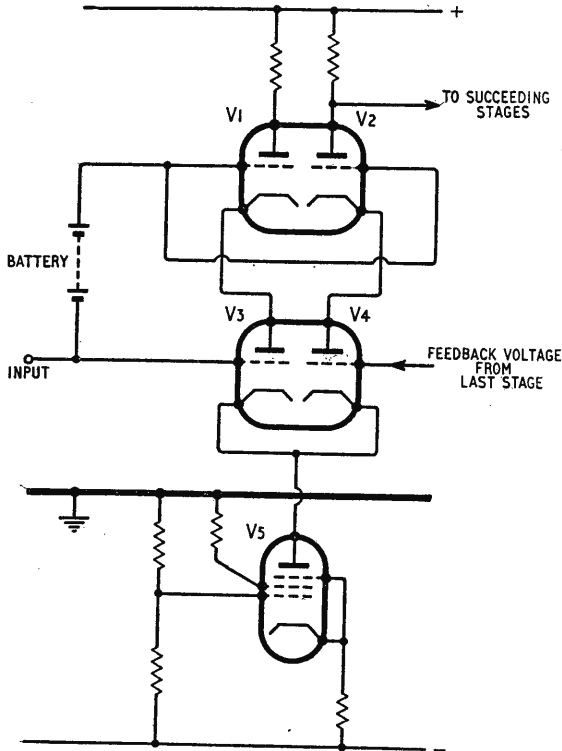

Fig. 11. Basic precision difference amplifier (Benjamin and Tomlin).

positive than that of the right-hand grid by a voltage equal to the increase in current divided by the working mutual conductance, in this example:—

$$\frac{0.15\text{mA}}{1\text{mA/V}} = 0.15 \text{ volt}$$

Both grid-cathode voltages must now be less since both valves have suffered a reduction of 50 V in anode-cathode voltage whilst one passes the same current as previously and the other even more current. In general, however, the simple long-tailed pair is a better difference amplifier than the cathode-injection stage, since the unbalance for a given input voltage is seen to depend on (mutual conductance) × (tail resistor), which can be made appreciably higher than the  $\mu$  of a single stage without bootstrap refinements.

The major source of imperfection in the long-tailed pair difference amplifier can be removed

by replacing the "tail" resistor by a good approximation to a constant current generator. The simple pentode "tail" as used in Fig. 7 of the first part of this article is usually convenient, giving a differential anode resistance of tens of megohms for values of  $R_o$  of about 2 or 3 kΩ, with the grid returned to a voltage of between +10 V and +20 V referred to the lower end of  $R_o$ . The long-tailed pair using this refinement is capable of good accuracy, since the extra "tail" current turned on or off with varying cathode voltage can be made negligible.

Even when the valves in the long-tailed pair are operated at constant current, the changing anode-cathode (or screen-cathode) voltage will cause slight unbalance unless the valve characteristics are identical. An ingenious circuit\* for overcoming this problem has been reported by Benjamin and Tomlin. Auxiliary cathode followers are used to maintain a constant anode-cathode voltage in each valve of the long-tailed pair, even though the input voltage is varying. The basic circuit is illustrated in Fig. 11, where V3 and V4 form the input long-tailed pair of a feedback circuit and V1 and V2 are cathode followers which maintain the anodes of V3 and V4 at a voltage  $e_b$  higher than that of the input grid, whatever the input voltage. The valve V5 provides an almost constant current to the common cathodes of V3 and V4. The load resistors for V3 and V4 are transposed to the anodes of V1 and V2 as shown.

In practice, the battery might be replaced by a neon tube connected to the long-tailed pair cathode (similar to the circuit of Fig. 5 in the first part). Alternatively where further stages are used to give a high loop gain, a method described by Benjamin and Tomlin is more convenient. In Fig. 12, V3 and V4 form the precision long-tailed pair triodes, using V1 and V2 to maintain substantially constant anode-cathode voltages and V5 to maintain substantially constant anode currents. The output from the precision long-tailed pair is taken from the anode of V1 and direct-coupled to the amplifying stage V6 as shown. The coupling between V6 and the output cathode follower V7 uses a further constant-current network. The high differential anode resistance of V8 ensures that almost the full voltage excursion at the anode of V6 appears at the grid of V7. When the overall gain is made unity, the output voltage will exactly equal that at the input and also the voltage on the grid of V7 will be almost equal to that at the output, being slightly larger in fact, due to the slight loss in V7. Due to the absence of attenuation in the coupling network between V6 and V7, it may therefore be assumed that at the tapping point in the resistors in this coupling network, the voltage is also equal to that at the input, except for a positive bias, and a tapping point may therefore be chosen to provide the correct drive voltage for the cathode followers V1 and V2.

The z.f. loop gain of the circuit in Fig. 12† is about 10,000 and it is seen that a fraction (loop gain)/(1 + loop gain) of the output voltage is fed back to the input precision long-tailed pair, no allowance being made for imperfect subtraction of the two grid voltages.

The 500-ohm "balance" potentiometer in the cathode circuits of V3 and V4 enables the output

\* Included in a publication of the Royal Naval Scientific Service (May, 1954)

† This is a variant suggested by the author.

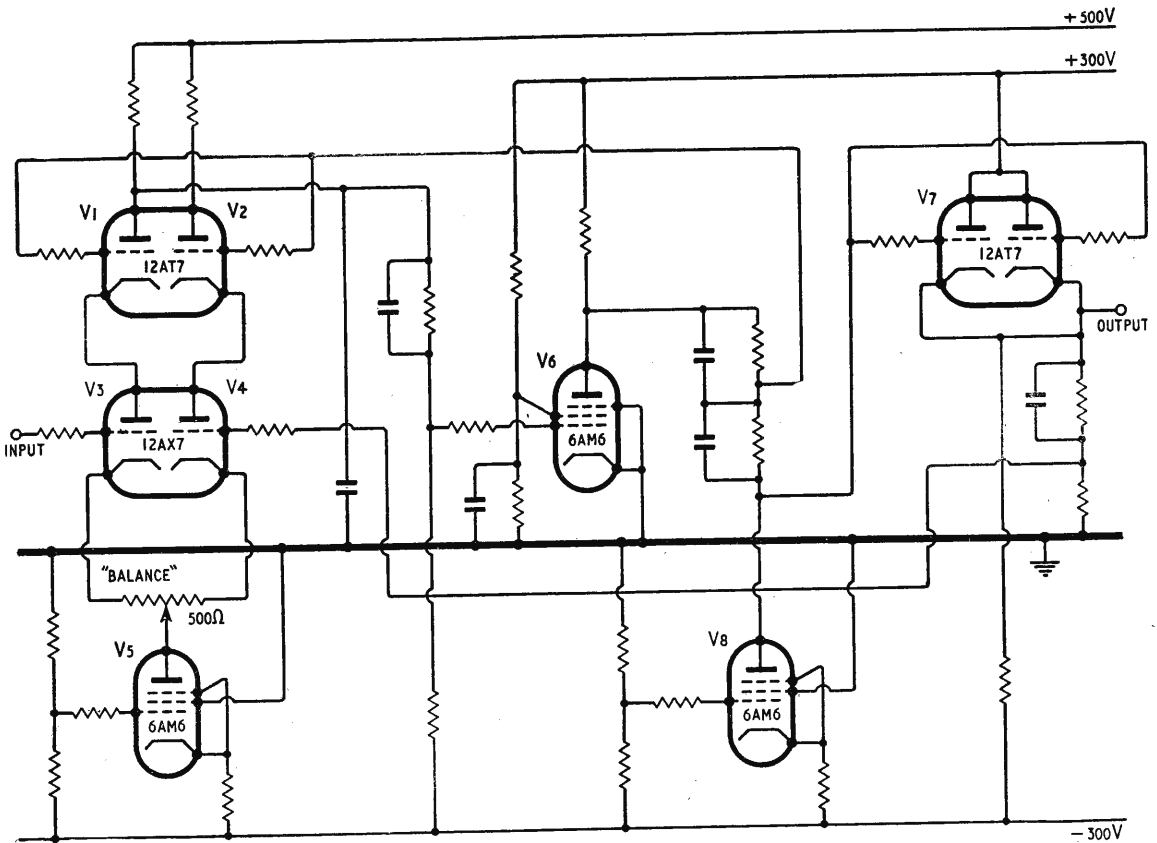

Fig. 12. Multi-stage cathode follower with precision difference circuit.

to be set to zero for zero input, and this initial adjustment for V3 and V4 grid-base symmetry once set, should be independent of the varying input voltage. The h.f. gain is about twice the z.f. gain due to the z.f. loss in the coupling network at the grid of V6.

The loop gain is quite high and, as in the circuit of Fig. 10, it is necessary to increase the time constant of one of the lags in order to ensure h.f. stability. The anode load resistor of the second triode is shown padded with the  $0.01 \mu\text{F}$  capacitor, choosing a point in the loop where the signal level is small so that the

increased time constant is less likely to cause overloading with high-frequency signals.

It is interesting to note that in the precision long-tailed pair, the triodes V3 and V4 (Figs. 11 and 12) are enabled to give a stage gain of the full value of their amplification factor  $\mu$ , by virtue of their constant anode-cathode voltages.

**Setting-up Procedure for Unity Gain Cathode Followers.**—A simple but effective method of setting the “balance” and “set gain” adjustments for a multi-valve cathode follower of the types discussed (except that of Fig. 8 which gives an overall phase reversal) is illustrated in Fig. 13. The 0-50 mV meter is switched as shown to read either output with earthed input (“set balance” position), or the difference between output and input (“set gain”) position. Progressive setting of each control alternately until the meter reads zero in both positions is seen to set up the conditions of zero quiescent output voltage simultaneously with exactly unity gain for a 30-V, signal (i.e. about half the overload level). For the circuits with extremely high loop gain (Figs. 10 and 12), a somewhat more sensitive millivoltmeter would be necessary if the setting is required to the utmost accuracy made possible by the precision of the circuits.

Fig. 13. Test circuit for cathode followers.

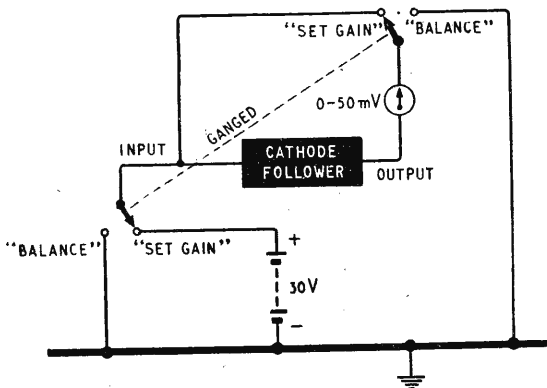

**“Portable Transistor Receiver”:** An  $8\text{-}\mu\text{F}$  electrolytic capacitor ( $C_{33}$ ) should be inserted in the lead from  $R_{14}$  to the earth line in the circuit diagram of this set on page 341 in the July issue. It should be connected with the positive lead to earth.

# Limiters and Discriminators for

## 5.—MEASUREMENT OF A.M. SUPPRESSION RATIO : TYPES OF LIMITER

**T**HE purpose of a limiter stage in a f.m. receiver is to reduce the magnitude of the amplitude-modulation component of an applied signal. The performance of a limiter may be judged by the degree of reduction of the modulation depth which it achieves, and this degree of reduction may be termed the a.m. reduction factor. However, a figure for the reduction of the modulation depth would not be directly applicable to self-limiting detectors such as the ratio detector. Furthermore, many discriminators have some degree of inherent a.m. rejection. For example, with a perfectly balanced Foster-Seeley discriminator there is zero output when the carrier is at the centre frequency and hence no output if the carrier is amplitude modulated. Thus a criterion is required which provides a figure of merit for a combination of limiter and discriminator, and which is applicable to self-

ment of the a.m. suppression ratio is that recommended by the B.B.C. Research Dept. The modulation depth of both a.m. and f.m. components of the test signal is 40 per cent ( $\pm 30$  kc/s frequency swing for the f.m. component) and the frequencies of the f.m. and a.m. components are 100 c/s and 2 kc/s respectively. The measurement is carried out as follows.

The apparatus under test is fed from a signal generator which can be modulated simultaneously in amplitude and frequency. The a.f. output is fed to a power-measuring instrument, preceded by a standard aural weighting network. (This network has a frequency response substantially flat in the region of 2 kc/s, where measurements are made, and therefore does not appreciably affect the measurements, save in exceptional circumstances, as, for example, when the a.m. component produces a substantial output of high-order harmonic components.) The input signal is set to the required amplitude for the test, and is first modulated by f.m. only to a swing of 35 kc/s by a signal at 2 kc/s. The a.f. power output  $P_1$  is then measured. (If the apparatus under test is a complete receiver, the gain control is adjusted to give the standard power output of 50 mW). The value of 35 kc/s frequency swing is greater than the modulation depth of 40 per cent specified, and is used to allow for the effect of a 50 microsecond de-emphasis network, so that the a.f. power output is the same as that which would be obtained with a signal of  $\pm 30$  kc/s frequency swing at 100 c/s.

The frequency-modulating signal is then set to 100 c/s, and the frequency swing to  $\pm 30$  kc/s. The amplitude modulation signal at 2 kc/s is then applied, with a modulation depth of 40 per cent. The fundamental-frequency component in the output due to the frequency modulation is then filtered out by means of a high-pass filter having a cut-off frequency of 250 c/s. The a.f. power output  $P_2$  due to the remainder of the signal is then measured. The a.m. suppression ratio is then the ratio of  $P_1$  to  $P_2$  expressed in decibels.

It was mentioned earlier that the Foster-Seeley discriminator has some degree of inherent a.m. rejection, and its a.m. suppression ratio can be calculated as follows. In an ideal discriminator of this type, the a.f. output is very nearly equal to  $I_f$ , over a region near the centre frequency, where  $I$  is the magnitude of the input signal current, and  $f$  is the difference between the signal frequency and the centre frequency. If the input current  $I$  is amplitude modulated, its value is given by  $(1+m \cos \omega_2 t) I$ , where  $m$  is the amplitude modulation depth expressed as a fraction,  $\omega_2 = 2\pi f_2$ , and  $f_2$  is the frequency of the a.m. component. If the f.m. component has a frequency of  $f_1$ , then the a.f. output is proportional to  $(1+m \cos \omega_2 t) \cos \omega_1 t$ . Such an output gives rise to oscillograms of the type shown in Fig. 1. The expression for the a.f. output

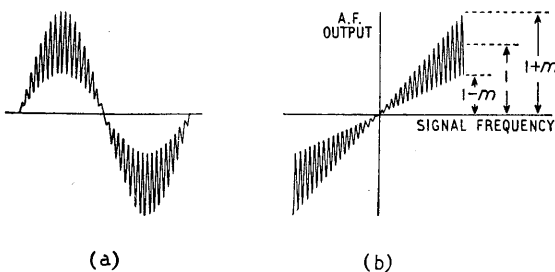

Fig. 1. Oscillograms of a.f. output from perfectly balanced Foster-Seeley discriminator with input signal simultaneously modulated in amplitude and frequency (a) with sawtooth time-base (b) f.m. component applied to X plates as time base.

limiting discriminators. Such a criterion is obtained by employing a test signal modulated simultaneously in frequency and amplitude, and measuring the ratio of the components of the output signal due to the two components of the signal modulation respectively. This criterion is termed the a.m. suppression ratio. If a limiter has a given a.m. reduction factor, it would appear that its effect, in combination with a given discriminator, would be to increase the a.m. suppression ratio by an amount equal to the a.m. reduction factor. However, this is not always true as the limiter may introduce spurious f.m. in the course of its limiting action.

However, there is general agreement as yet as to the test conditions to be employed in making a measurement of a.m. suppression ratio; the result is that any one device may have a number of values of a.m. suppression ratio, depending on the conditions of measurement. There is also the undesirable result that the minimum figure for the a.m. suppression ratio of a receiver, under given conditions of operation, is subject to a margin of uncertainty, unless the conditions adopted for the measurement of the a.m. suppression ratio are defined. In this article, the definition and measure-



# F.M. Receivers

By G. G. JOHNSTONE\*, B.Sc.

(Concluded from page 280 of the June 1957 issue)

waveform is precisely similar to the expression for an amplitude-modulated carrier. It can be resolved into three components, corresponding to the carrier and sidebands of an a.m. signal. However, the "carrier" component in this case is the fundamental frequency component of output due to the frequency modulation, and the power output due to this component alone may be taken as unity. When this component due to the frequency modulation is filtered out, there remains two components due to the amplitude modulation. These are of equal amplitude,  $m/2$ , and have frequencies  $(f_1 - f_2)$  and  $(f_1 + f_2)$ . With the test frequencies postulated, i.e., 100 c/s for the f.m. component and 2 kc/s for the a.m. component, these two residual components of the a.f. output have frequencies of 1900 c/s and 2100 c/s. The total power output is then proportional to  $2(m/2)^2 = m^2/2$ . With the value of  $m$  postulated, 0.4, this power output is proportional to 0.08. Thus the ratio of the power outputs due to the f.m. component to that due to the a.m. component is 1 : 0.08, i.e., some 11 dB. However, this figure includes no allowance for the effect of the de-emphasis network, which introduces a loss of some 1.5 dB in the region of 2 kc/s; thus the value of the a.m. suppression ratio is some 12.5 dB.

The effect of a change of test conditions upon the value of the a.m. suppression ratio can be judged from the foregoing; if the amplitude modulation depth used had been 30 per cent., the a.m. suppression ratio would be 15 dB.

If the input signal carrier frequency is not precisely at the centre frequency of the discriminator characteristic, the a.m. suppression ratio alters. The output signal, with the input signal simultaneously modulated by a.m. and f.m., is then proportional to  $(1 + m \cos \omega_2 t)(F \cos \omega_1 t - f_0)$ , where  $f_0$  is the displacement of the carrier frequency from the centre frequency of the discriminator, and  $F$  is the frequency swing of the f.m. component. The types of oscillogram obtained under these conditions are shown in Fig. 2. In addition to the two components, each of amplitude  $m/2$  relative to the fundamental frequency f.m. component, discussed previously,

Fig. 2. Carrier frequency displaced by frequency  $f_0$  from centre frequency.

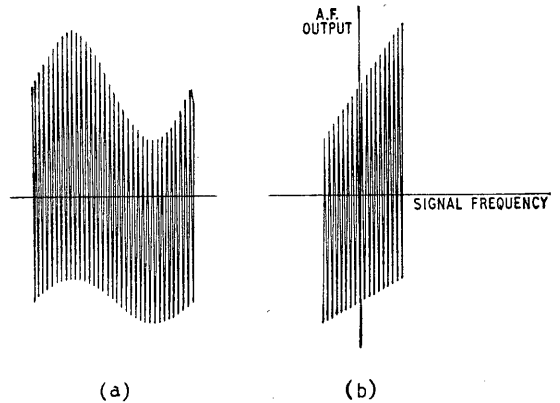
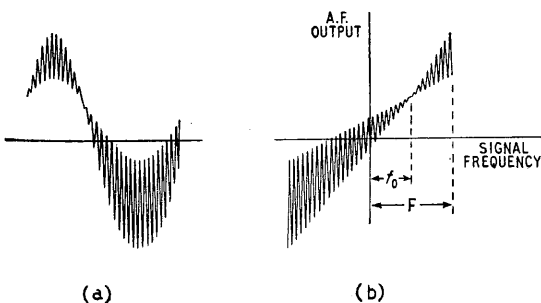

Fig. 3. Oscillograms of a.f. output from a counter-type discriminator with input signal modulated simultaneously in amplitude and frequency (a) with sawtooth time base (b) f.m. component applied to X plates as time base.

there is now a further a.f. component of amplitude  $mf_0/F$  at the a.m. modulating frequency  $f_2$ . The power output due to the a.m. component is thus increased to  $(m^2/2) + (m^2 f_0^2 / F^2)$ . If, for example, the carrier frequency is displaced 30 kc/s from the centre frequency, the power output due to the a.m. component rises from 0.08 to 0.24, i.e., the a.m. suppression ratio falls by some 4.8 dB. to 7.7 dB.

This special case was considered because it can be extended to other discriminators. For example, the counter-type discriminator gives zero output at zero frequency, and its output is proportional to the input signal amplitude and the signal frequency. Thus if a counter-type discriminator is operated at a centre frequency of 200 kc/s, a typical figure, the value of  $f_0$  is 200 kc/s. The type of oscillogram obtained with the input signal modulated simultaneously in amplitude and frequency is shown in Fig. 3. Applying the formulae given previously, the a.m. suppression ratio is - 6.1 dB. Thus a counter-type discriminator requires that very careful attention be given to the performance of the preceding limiter.

The minimum desirable value for the a.m. suppression ratio measured in the manner described above, depends upon the type of a.m. interference encountered, and upon the class of service desired. For a broadcasting service, giving a signal output of good quality, a minimum value of 30 dB would seem to be necessary, and it would appear preferable that the ratio should be greater than 35 dB. It is doubtful if any aural change is perceptible if the value is increased beyond 40 dB.

Although the a.m. suppression ratio provides an excellent criterion of performance, another important factor must not be overlooked. This is the range of input signal amplitude over which a.m. rejection is maintained. The test for a.m. suppression ratio

\*B.B.C. Engineering Training Dept.

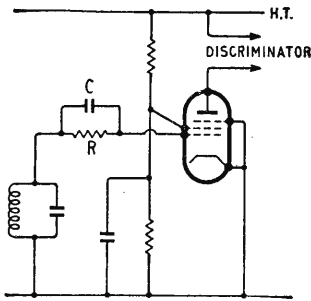

Fig. 4. Basic circuit of grid limiter.

explores limiting performance over a range of 40 per cent. modulation depth, but it is important to know the maximum modulation depth which the limiter can handle. Dependent upon the type of limiter, there may be a minimum signal amplitude below which limiting action fails, or alternatively, there may be a maximum modulation depth which the limiter will handle. In general, limiting action fails when the signal amplitude is decreasing. If the limiter has a minimum value of input signal below which limiting action fails, the limiter is said to have a threshold value. The maximum modulation depth in the "downward" direction then varies with the amount by which the mean signal amplitude exceeds the threshold. With limiters of the type which have a fixed "downward" modulation handling capacity, there is no fixed threshold. However, with such limiters, the a.m. suppression ratio generally falls with mean carrier amplitude, and there is thus a quasi-threshold fixed by the input signal amplitude above which the a.m. suppression ratio is satisfactory.

For most purposes, it would seem desirable that satisfactory limiting action should be maintained for "downward" modulation of 50-70 per cent., although in some locations the depth of amplitude modulation due to reflections may exceed this value. Thus if a limiter has a threshold input of 1 volt for satisfactory limiting, the mean carrier level should normally be greater than 2-3 volts. With a limiter or self-limiting discriminator (e.g., ratio detector), having maximum "downward" modulation handling capacity, this modulation handling capacity is fixed in the course of design and should be in the region 50-70 per cent.

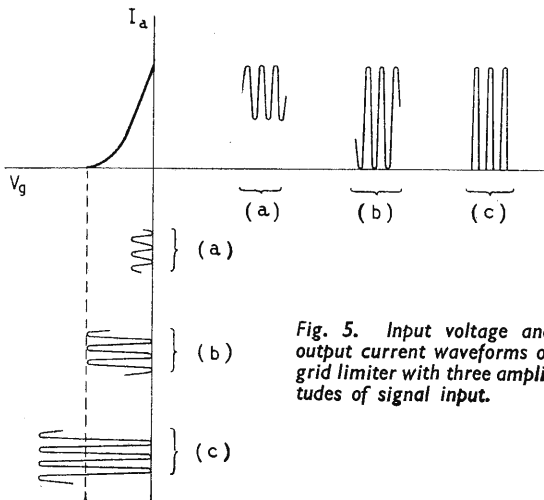

Fig. 5. Input voltage and output current waveforms of grid limiter with three amplitudes of signal input.

**Grid Limiter.** The grid limiter has been widely used in f.m. receivers, particularly in conjunction with Foster-Seecley discriminators. It comprises a pentode operated with a low screen voltage, fed at the control grid through a self-biasing network, as shown in Fig. 4. No cathode bias is usually employed, and one of the reasons for employing a low screen voltage is to prevent the valve drawing excessive current in the absence of an input signal. The low screen voltage also results in the valve having a short working grid-base, so that the limiting action commences with a relatively small input. The action of the circuit is as follows.

The grid and cathode of the valve function as a diode detector. When the input signal is positive-going, grid current flows at the tip of the cycle, and the capacitor C is charged, biasing the valve. With a reasonably large value grid resistor R (i.e., large compared with the resistance of the grid-cathode path when conducting), the bias so adjusts itself that grid current flows only on the tips of the positive peaks of the input signal. As the input signal amplitude increase from zero, the valve behaves first as a class A amplifier. When, however, the input signal amplitude exceeds half the cut-off bias, the valve is driven beyond cut-off on the negative-going peaks of the signal. As the input signal amplitude increases still further, the periods when the valve conducts become progressively shorter, as shown in Fig. 5.

The resultant anode current waveform may be

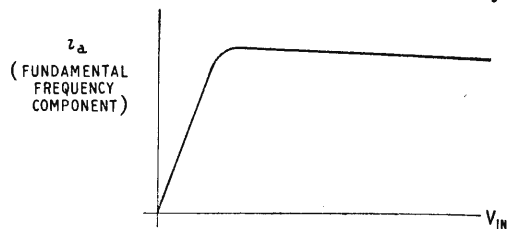

Fig. 6. Fundamental frequency component of anode current plotted against input voltage for typical grid limiter.

analysed into components at the input signal frequency, and harmonics of this frequency. We may plot this fundamental-frequency component against input signal amplitude and obtain a curve of the type shown in Fig. 6. It will be seen that this fundamental-frequency component rises linearly at first with increasing input signal amplitude, until a "threshold" is reached, beyond which the output current is substantially independent of input signal amplitude. With a typical circuit of this type, comprising a pentode having a screen voltage of the order of 40-50 volts, the threshold input signal is of the order of 1 volt.

In practice, the portion of the curve above the threshold is not flat, but generally tends to fall slowly. This tendency may be minimized by careful choice of screen feed resistor, anode feed resistor and grid resistor. The selection of these components is usually done on test. A well-designed grid limiter will have an a.m. reduction factor of the order of 20-30 dB.

The grid limiter of the type described above has one major disadvantage. This is bound up with the time constant CR of the grid circuit components.

(Continued on page 381)

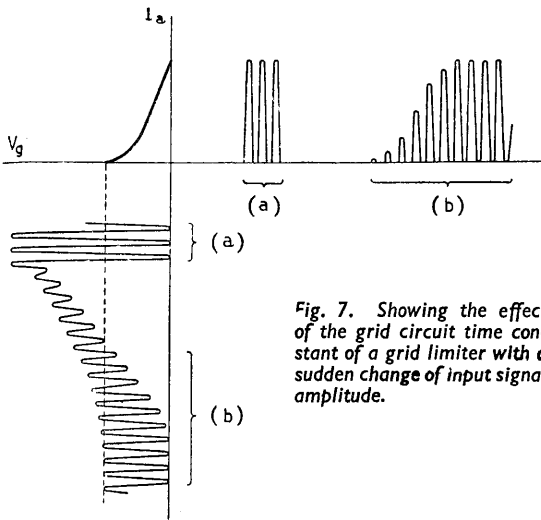

Fig. 7. Showing the effect of the grid circuit time constant of a grid limiter with a sudden change of input signal amplitude.

For satisfactory operation, the bias developed across the capacitor  $C$  should change instantaneously with any change of signal amplitude so that the positive-going peaks of the signal are always at zero bias. With an increasing signal amplitude, this condition is very nearly fulfilled, since the capacitor is charged through the relatively low resistance of the grid-cathode path. When, however, the input signal amplitude falls, the capacitor has to discharge through the resistor  $R$ , and whilst this is happening, the amplitude of the signal may be insufficient to cause the valve to conduct at all, or only partially. This is shown in Fig. 7. Thus, to ensure rapid discharge of the capacitor when the signal amplitude is decreasing, the time constant  $CR$  must be small. The desirable value of the time constant depends upon the maximum rate of change of input signal encountered, and the problem is the same as that of avoiding "tracking" distortion in conventional diode detector. It can be shown that this form of distortion can be avoided if  $CR < 1/2\pi f m$ , where  $f$  is the modulation signal frequency, and  $m$  is the maximum modulation depth. To consider the simplest case, co-channel interference, if the wanted signal is at one extreme of the frequency swing, and the unwanted signal is at the other, the wanted signal will be amplitude modulated at a rate of 150 kc/s. If the ratio of wanted to unwanted signal is 2:1, then  $m$  is 0.5, and in this case  $CR$  must be less than 2.1 microseconds approximately. In practice a value in the region of 2.5 microseconds is frequently adopted.

The choice of values for  $C$  and  $R$  individually is limited in two ways. If  $C$  is made small, a capacitance potential divider with the input capacitance of the valve is formed, and the signal appearing at the grid is materially reduced. Thus there is a lower limit to the value of  $C$  which can be tolerated; if the valve input capacitance is 10 pF, this minimum value is of the order of 20 pF. If the value of  $R$  is reduced, the damping of the tuned circuit feeding the limiter is increased. Since the grid and cathode of the valve behave as a diode detector, the damping resistance is given by  $R/2\eta$ , where  $\eta$  is the rectification efficiency of the circuit. Thus if the preceding circuit has a dynamic resistance of 20 k $\Omega$ , the

minimum value of  $R$  would appear to be in the region of 40 k $\Omega$ , giving a reduction of approximately one-half in the working  $Q$ -value of the tuned circuit feeding the limiter. Values of  $C$  and  $R$  often adopted for a time constant of 2.5 microseconds are 50 pF and 47 k $\Omega$  respectively.

There is one variant of the grid limiter which is worthy of special mention. This is the form of grid limiter in which the valve employed has a high input resistance at the input grid, even when driven positive with respect to the cathode. Valves of this type have been discussed before in the section on gated-beam discriminators. Thus the valve type 6BN6 may be employed, and because of its high input resistance, it may be operated without the grid-current biasing network. The valve is biased to a class A operating condition in the absence of a signal by the cathode components, and when the signal amplitude is sufficiently large, square waves of anode current are generated, the magnitudes of which do not vary appreciably with input signal amplitude above the threshold value. This type of limiter thus has the advantage over the conventional type of grid limiter that its operation is not affected by the action of the grid circuit time constant. The damping presented to the input circuit under operating conditions is of the order of 20 k $\Omega$ .

A similar type of action to that described above may be secured with a normal pentode by inserting a resistor in series with the grid as shown in Fig. 8. When the signal drives the grid positive with respect to the cathode, the series resistor limits the flow of grid current, and ensures that the grid is not driven appreciably positive with respect to the cathode. The behaviour of the circuit is thus essentially similar to that of the 6BN6 type of limiter described above, the input signal driving the valve between anode current cut-off and its value at zero bias. However, there is one major disadvantage

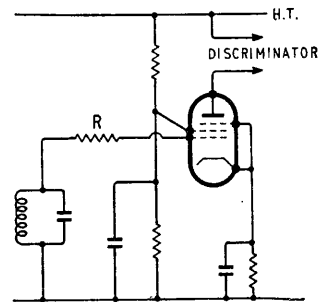

Fig. 8. Series-resistor grid limiter.

of this circuit: it is not suitable for use at high frequencies because of the effect of the grid-cathode capacitance of the valve. This, in conjunction with the series resistor, introduces a loss of signal increasing with increasing frequency. The circuit is thus useful only for maximum frequencies of the order of hundreds of kilocycles per second.

Another form of grid limiter sometimes used has a tuned circuit directly coupled to the grid of a pentode stage operated with a small bias. Grid current then damps the circuit, and gives a limiting action.

**Anode Limiter.**—The anode limiter relies for its action upon the existence of the "knee" of the  $I_a$ - $V_a$  characteristic of a pentode. The valve is operated with a high value of anode load impedance,

so that when the grid voltage is a few volts negative, the anode voltage "bottoms" at the value given by the intersection of the load line and the portion of the  $I_a-V_a$  curve below the "knee" of the characteristic, as shown in Fig. 9. The anode-current/grid-voltage characteristic is modified by the "bottoming" action to the form shown in Fig. 9(b). If the valve is biased to the working voltage  $V_g$  indicated in Fig. 9(b), symmetrical limiting of the input wave form occurs. Such a limiter was described by Scroggie\* for use with a counter-type discriminator with the added refinement that a series grid resistor was used to assist the limiting action when the grid-cathode voltage was driven positive.

**Dynamic Limiter**—The dynamic limiter operates by presenting a varying impedance to a source of signal, the impedance varying in such a way as to tend to maintain the output signal at a constant amplitude. In its simplest form the circuit is shown in Fig. 10. We shall assume that the diode has a very low forward resistance compared with its load resistance. Then under quiescent conditions, the damping of the tuned circuit by the diode circuit is approximately equivalent to a parallel resistance  $R/2$ . This resistance is usually comparable with, or less than, the dynamic resistance of the tuned circuit. The time constant of the load circuit of the diode is made large compared with the period of the a.m. signals it is desired to suppress. Under quiescent

conditions the diode load capacitor charges to a voltage just less than the peak signal voltage. If now the signal amplitude tends to increase, the diode will take increasing current on the peaks of the signal, in an attempt to increase the voltage across the capacitor. If the capacitor is large, however, the voltage across it cannot increase appreciably and the damping of the tuned circuit will increase, so that the load presented to the driving valve falls, and the gain from grid to anode decreases. The decrease in gain largely offsets the increase of input signal amplitude, so that there is only a small change in output signal amplitude.

If the input signal amplitude decreases, the opposite effect occurs, the damping decreasing, so that the driving valve gain rises, offsetting the fall in signal amplitude.

However, there is a lower limit below which the limiting action ceases. This occurs when the signal across the tuned circuit falls below the voltage across the diode load capacitor, and the diode fails to conduct on the peaks of the signal. Below this signal amplitude, the driving valve behaves as a linear amplifier. The range over which limiting is maintained can be calculated from the graph of Fig. 11. The curve of  $E=R_d i$ , where  $R_d$  is the dynamic resistance of the tuned circuit, shows the relationship between the output voltage and the current supplied by the driving valve in the absence of the diode circuit. The curve of  $E=R' i$  is the curve obtained when diode limiter is connected,  $R'$  being equal to

\* Wireless World (April, 1956)

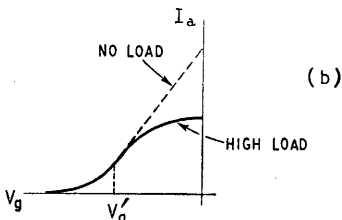
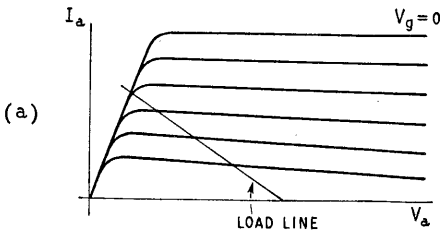

Fig. 9 (a) Showing the "bottoming" effect occurring with an anode limiter with a high-value anode load. (b) Modification of the  $I_a-V_g$  curve of the valve by the high-value anode load.

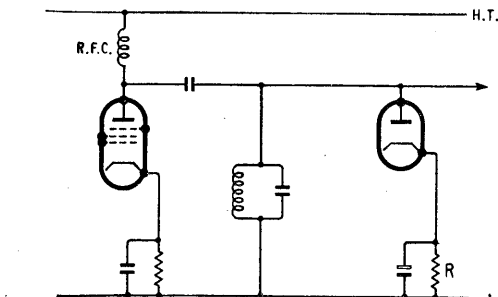

Fig. 10. Basic circuit of dynamic limiter.

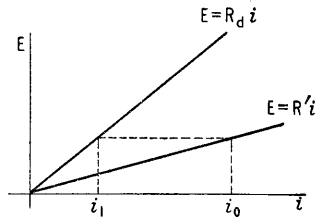

Fig. 11. Showing graphical construction for determining maximum "downward" modulation handling capacity of dynamic limiter.

$R_d$  in parallel with  $R/2$ , the equivalent damping resistance due to the diode circuit (the diode rectification efficiency is assumed 100 per cent.). In plotting this graph, the input current is assumed to change its amplitude very slowly, so that at each stage the diode load capacitor charges to the peak value of the output voltage.

Under dynamic conditions, when the input signal amplitude decreases from the quiescent value  $i_0$  the charge on the diode load capacitor does not have time to change appreciably, and the output voltage amplitude remains constant until the input current falls to the value  $i_1$ , when the diode ceases to conduct; the equivalent damping resistance due to the diode circuit is then infinite. If the input current decreases further, the output voltage falls linearly, following the curve  $E=R_d i$ . Thus the maximum "downward" modulation depth which the limiter will suppress is given by  $(i_0 - i_1)/i_0$ . From the geometry of the figure, this modulation depth is given by  $1 - (i_1/i_0) = 1 - (R'/R_d)$ . But  $R' = R_d(R/2)/(R_d + R/2)$ , so that this maximum value is given by  $R_d/(R_d + R/2)$ . Thus for good "downward" modulation handling capacity,  $R_d$  must be large compared with  $R/2$ . This means that the tuned circuit is heavily damped under quiescent conditions, and hence the gain of the driver stage is low.

Because a diode employed in a practical circuit

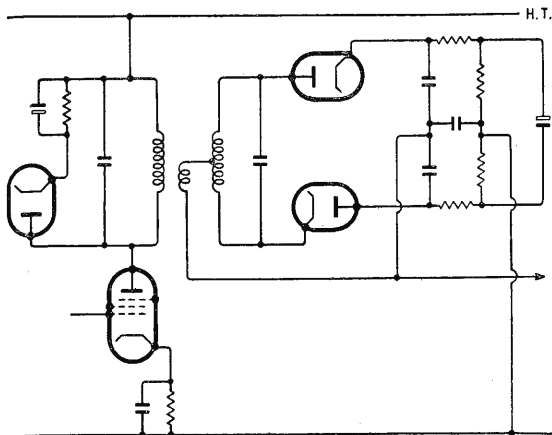
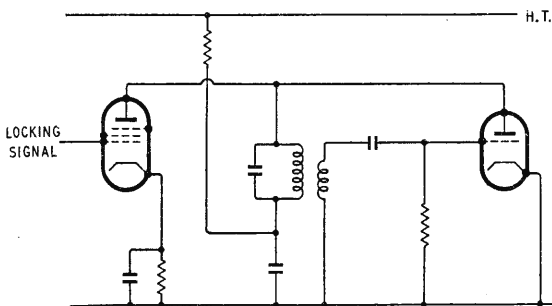

Fig. 12. Ratio detector with added dynamic limiter.

Fig. 13. Basic locked-oscillator circuit.



cannot have 100 per cent. rectification efficiency, the limiting action is not perfect, and the a.m. reduction factor is usually of the order of 10-20 dB. This type of limiter offers no protection against long-term changes of input signal amplitude or slow flutter due to reflections from aircraft, as the diode load capacitor will charge to the mean value of the input signal amplitude. It has, however, the advantage that the limiting action is maintained over a constant range of modulation depth at all levels of input signal amplitude, down to the quasi-threshold value at which the diode efficiency falls to the point where the limiting action is seriously impaired.

The damping imposed on the tuned circuit under operating conditions varies with the amplitude modulation of the input signal, and so, therefore, does the pass band of the tuned circuit.

The dynamic limiter may be employed with advantage in combination with those forms of limiter/discriminator where the a.m. suppression ratio falls somewhat short of the desirable value. In particular, it may be employed with a ratio detector, connected in parallel with the primary circuit, as shown in Fig. 12.

**The Locked Oscillator.** The type of oscillator used widely in receivers employs grid-current biasing, and in this resembles the grid limiter. The limiting action which takes place stabilizes the oscillation amplitude. Thus if an oscillator of this type can be made to change in frequency in step with an applied signal, the oscillator output amplitude will tend to remain constant independently of changes in the input signal amplitude. A suitable arrange-

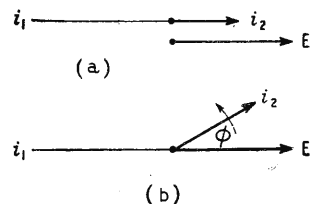

Fig. 14. Vector diagrams for circuit of Fig. 13.

ment for locking an oscillator to an applied signal is shown in Fig. 13.

Consider firstly the conditions of operation when the applied signal frequency is equal to the free-running frequency of the oscillator. The equilibrium relationship between the vectors representing the oscillator valve anode current ( $i_1$ ), the locking valve anode current ( $i_2$ ) and the voltage across the tuned circuit ( $E$ ) are as shown in Fig. 14(a). The current vectors are in anti-phase, and the oscillator valve anode current is also in anti-phase with the tuned circuit voltage, indicating that the oscillator valve is equivalent to a negative resistance in parallel with the tuned circuit. The locking valve current is in phase with the oscillator voltage, corresponding to a damping resistance of magnitude  $E/i_2$ . If now the locking signal frequency increases, the locking valve anode current vector will commence to rotate in a clockwise direction, as shown in Fig. 14(b). There will now be a component of the locking signal current in quadrature with the oscillator voltage, i.e. the locking valve now behaves as a resistor and reactor in parallel. The reactance is equivalent to an inductive component under the conditions postulated, and this equivalent inductance re-tunes the oscillator, circuit to a higher frequency. Equilibrium is restored when the oscillator frequency is equal to that of the locking frequency, i.e. synchronization has been achieved. If the phase angle between the locking valve anode current and the oscillator voltage in this equilibrium condition is  $\theta$ , then the reactance of the equivalent parallel inductance is  $E/i_2 \sin \theta$ . The range over which locking occurs is limited because when the phase angle between the oscillator voltage and the locking valve anode current is equal to 90 degrees, the equivalent parallel inductance is at its minimum value; any increase of phase angle beyond 90 degrees increases the magnitude of the equivalent parallel inductance. At the minimum value of inductance, the reactance is given by  $E/i_2$ . For maximum effect, this reactance should be as small as possible, and hence for locking over a wide frequency range,  $E$  should be small, and  $i_2$  large. Further, the main tuning inductance of the oscillator circuit should be as large as possible, for the equivalent parallel inductance to have maximum "pulling" effect.

The argument applied above can be applied also when the locking signal frequency is below that of the oscillator; in this case the locking valve behaves as an equivalent capacitor.

The relationship between the oscillator frequency and the locking frequency is as shown in Fig. 15(a). Outside the locking range, the oscillator frequency tends to swing between wide limits, as the heating effect with the locking signal produces alternately the effect of a parallel capacitance and parallel inductance; the mean frequency tends to follow the curves shown dotted in Fig. 15(a). In practice, however, non-linearity in the oscillator valve causes

the oscillator to lock over a succession of small ranges at fractional multiples of the locking signal frequency (e.g. 10/9, 9/8), as shown in Fig. 15(b).

The greater the amplitude of the locking signal current, the greater is the frequency range over which locking is maintained. When the input signal is amplitude modulated, therefore, the minimum value to which the input current falls must be sufficient to lock the oscillator over the full frequency range of the f.m. signal. The locked oscillator thus resembles the grid limiter, in that there is a threshold limit of signal which must be exceeded for satisfactory performance. The "downward" a.m. modulation handling capacity is determined by the ratio of the mean input signal amplitude to this threshold amplitude.

The locked oscillator limiter may also suffer from the effects of the time constant of the grid-biasing components in the same way as the grid limiter, and the grid components must thus be chosen with care.

Examples of the locked oscillator limiter were given in Part 4 of this series. This type of limiter is not now widely used. One of its principal disadvantages is the feedback of the oscillator signal to early i.f. stages, which can lead to overloading in the i.f. amplifier. A number of schemes have been proposed for locking an oscillator at a sub-multiple of the intermediate frequency to avoid this effect. Additionally, a single stage locked oscillator limiter-discriminator has been described by Bradley (see references).

**The "Clipper."** This type of limiter employs two triodes cathode coupled as shown in Fig. 16. It thus comprises a cathode follower driving an earthed-grid triode. Under quiescent conditions, both triodes are conducting, and each is biased approximately to the mid-point of its grid base. If now the input signal at the grid of V1 increases positively, the anode current of V1 increases. The cathode potential therefore rises, and this in turn leads to a decrease of anode current in V2. In fact,

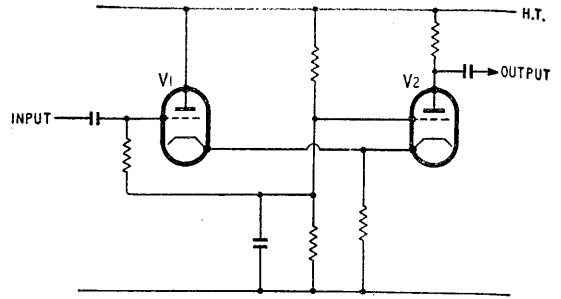

Fig. 16. Basic circuit of the "clipper" type of limiter.

the common cathode potential rises by an amount equal to half the increase of V1 grid potential. If the input to the grid of V1 increases sufficiently, the common cathode potential rises to the point where anode current is cut off in V2. The degree of feedback applied to V1 then increase sharply, and V1 behaves as a true cathode follower. During the rise of common cathode potential the anode of V2 rises to h.t. potential, and when anode current is cut off, it remains at this value, i.e. the output signal is then limited.

When the input signal at the grid of V1 is negative-going, the common cathode potential falls, and the anode current in V2 rises. Whilst both valves are conducting, the change in cathode potential is approximately half that of V1 grid. If the input signal rise to a value sufficiently negative, anode current in V1 is cut off, and there is no further change in common cathode potential. Thus this circuit "clips" the input signal symmetrically, providing a chain of square-wave output pulses.

This form of limiter is very useful at low frequencies, and may be used with input signal frequencies of the order of a few Mc/s. It has a fixed threshold of the order of 5-10 volts above which limiting occurs. As it does not depend for its action upon the charging and discharging of capacitors, it is free from "blocking" effects.

The author wishes to record his thanks to Dr. G. J. Phillips and Mr. J. G. Spencer for helpful discussion.

#### REFERENCES

- "Locked-in Oscillator for TV Sound" by M. S. Corrington, *Electronics*, March, 1951.
- "Single-stage F.M. Detector" by W. E. Bradley, *Electronics*, December, 1949.
- "A Study of Locking Phenomena in Oscillators" by R. Adler, *Proc. I.R.E.*, June, 1946.

### Nickel-Iron Laminations

THE new British Standard BS2857/1957 covers laminations for transformers and chokes of 0.004, 0.008 and 0.015 in thick respectively and containing between 36 per cent and 75 per cent of nickel with the residue mainly or wholly iron.

Measurements of permeability are to be made normally at 50 c/s, but by arrangement between user and manufacturer audio tests can be effected at six frequencies between 300 c/s and 4,000 c/s, or at a single frequency of 800 c/s. Details are given of a method of testing for compliance with the minimum values of permeability laid down in the specification.

Copies of BS2857 are obtainable from the British Standards Institution, 2, Park Street, London, W.1, price 3s (3s 6d by post).

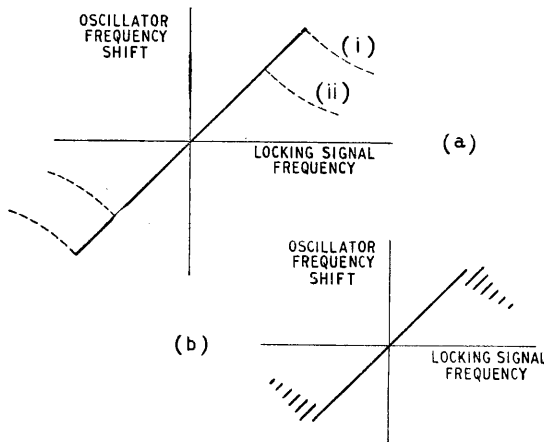

Fig. 15. (a) Locking of oscillator frequency to that of locking signal. The dotted portions of the curves indicate the mean value to which the oscillator frequency tends outside the locking range. Curve (i) is that for a larger locking signal input than curve (ii); (b) Showing locking of the oscillator frequency at fractional multiples of the locking signal frequency over restricted ranges outside the true locking range.

# "Rainbow 'Round my Shoulders"

An American Serviceman Faces Up to Colour Television

By JACK DARR\*

SOME several years ago, television came over the Arkansas Hills into our little town. It wasn't too far behind the bigger towns, at that. To most of the radiomen it came as no surprise: we'd heard rumours of its existence! We're speaking, of course, of the old-fashioned monochrome, or "B. & W." (black and white) TV, not the multi-hued version. "The papers were full of it," literally. In consequence of this, we felt pretty well at home when TV finally did put in an appearance. At least, we weren't perfect strangers! But we found the inevitable assortment of troubles not mentioned in the books: the normal ratio between "book-larin'" and practical experience still holds in this, as in every other trade! It was several years before we became as "at home" in the underside of a TV set as we were in radio chassis.

The average American serviceman accepted the advent of television as a challenge, as do servicemen everywhere in the world, whenever a new piece of equipment is introduced. He set out to learn all he could about it, and today, even in the smaller towns such as ours, there are several shops, staffed with well-trained technicians and provided with an astonishing array of modern test equipment. (This does not, of course, include *my* home town, and *my* competitors!)

## Literature

We accepted the advent of colour TV with the same aplomb that we had B. & W.: the magazines began to run articles about it, and are still doing so: the set-manufacturers put out study courses on the fundamentals of colour, some of them free, some at a very nominal figure. RCA, for instance, sent out an excellent course, prepared by RCA Institutes, beginning with the wavelength of coloured light and winding up with a detailed description of convergence and setup procedures for the latest sets then available. I obtained mine free by agreeing to buy a few hundred tubes! Other set-makers had similar material: Philco, for instance, published a single-volume course, illustrated in colours, showing test patterns, etc., to be found under certain conditions.

In addition to this, RCA, Philco, Hoffman, and others held "Colour Clinics," schools, in the larger cities, and some servicemen travelled many miles to attend them. Service meetings held by manufacturers and service groups became devoted almost exclusively to colour, and after a while even the most remotely situated serviceman could answer without hesitation when asked, "What angle is Green?" (299.4 degrees, by the way!) Fundamentals and theory came out of our ears: chromaticity diagrams became as familiar to us as our own front lawns. All we needed now was some practical experience!

Came the day when a customer in our town, possessed of more money than most of us, ordered

a colour set, and called upon us to set it up. Came also the day when we discovered that all was not going to be multi-chrome beer and skittles! Came also our first experiences with what one of my associates described with some bitterness as "pink trees and purple people!" We made the same discovery all over again, that we'd made with B. & W. TV. Easy as it might sound in the books, actually sitting down on one's haunches before a huge colour TV receiver, confronted with an array of controls bearing such exotic names as "Green Horizontal Dynamic Slant" and "Blue Vertical Static Parallax" was a far cry from sitting at home in an easy chair reading about it!

## Preliminary Adjustments

To set up a colour TV receiver correctly, a series of adjustments must be made. These should be made after the set is installed in the owner's home, as any moving of the set afterwards disturbs them; not from a shifting of the adjustments themselves, but from the changing magnetic fields from metallic objects, such as radiators, etc. This process is known as "convergence," although it covers a great deal more than that. Strictly speaking, the convergence adjustments are those made to enable the beam from each of the three guns in the c.r.t. to strike its own colour dot on the screen, through the same hole in the shadow mask. Improper convergence or, indeed, errors in any of the other adjustments, means that the set will not only not give a good colour picture, or even a good black-and-white picture: such ill effects as colour fringing, tinting, etc., will interfere with the use of the set. This is the "rainbow 'round the shoulder" effect so common in badly adjusted sets.

RCA and most other manufacturers recommended the use of a "dot generator" for alignment, a signal generator which creates a pattern of small dots on the screen. Test equipment makers leaped eagerly into the breach, and assorted pattern generators were soon available at all prices.

After the proper test gear is assembled, then arises the problem of learning how to use it. Fortunately, the distributor sent along his own expert technician, a happy character named Gene, complete with dot generator and other equipment. His main purpose was to check me out on the set. He turned it on, and suggested that I make the first setup on it, to gain experience. Happily I agreed, and sat down in front of the monster. Thoughtfully, the maker had mounted all the adjustments on the front panel of the set, exposed by removing the knobs and a couple of small screws, after which a small panel

\*Ouachita Radio-TV Service, Mena, Arkansas, U.S.A.



came off, and there they were. These were all plainly labelled, a feature unfortunately sometimes omitted!

Gene handed me the instruction sheets, and stood back, hands in pockets, with a knowing grin on his face. I casually glanced at them, then laid them down, after locating the various controls. After all, hadn't I finished my colour TV correspondence course with honours? I knew all there was to know about it! Deftly I made the initial connections, finally obtaining a pattern of small multi-coloured dots on the screen, about an inch apart. Apparently, none of the blasted things was converged: I didn't see a white dot anywhere! This is one of the charming paradoxes of colour TV work: you must adjust for a complete *lack* of colour!

## Dot and Carry Two

Gene mildly suggested that I select a dot in the centre of the screen, since I had to start somewhere! This individual was selected, and I tentatively wiggled one of the adjustments. This resulted in the blue dot taking off wildly for the left side of the screen, winding up about a half-inch away from where I wanted it. Reversing the direction brought it back to the other side, then finally to centre, where it overlapped the red dot, anyhow. The green dots were still about 11 o'clock, high. Adjusting that control brought them down; it also moved the red dots over to about 2 o'clock. Adjusting the red dots brought them back: the blue dots, meanwhile, had apparently found something interesting going on over at the right side of the screen: at any rate they were all wandering off in that direction! Turning their control halted their flight and brought them back toward the centre, at the same time separating the red and green dots, so that I once again had a perfect triad: translated, this means that I was right back where I started!

At this point, we had to stop and revive Gene, who was rolling helplessly on the floor behind me. After we had administered restoratives, and wiped the tears from his eyes, and he had recovered some degree of coherence, we followed the standard American custom in such circumstances: we took a coffee break. Bringing the instruction sheets along, he tactfully explained to me that the main trouble was my complete ignoring of the instruction book! (This is an unusually frequent occurrence among us technicians: I recently read the instruction book on a piece of test equipment I'd owned for ten years, and discovered three things that I didn't know it would do!)

Back at the store we sat down with the instruction sheet, a very detailed and lucid piece of technical literature, and began at the beginning! First, as in B. & W., we made the vertical linearity and size adjustments: once convergence is started, these must never be touched. Next, we measured the high voltage on the tube, using a special test socket provided on the back of the set. After the horizontal size and linearity adjustments were checked, *then* we began the setup procedure.

First, under constant supervision, I made the purity adjustments. This consists of turning the blue and green guns off, through their gain controls, and adjusting pots, etc., for a pure red screen. This was slightly marred by patches of orange and magenta at the edges. Adjustments of small magnets

at the tube's rim failed to eliminate these completely, so we went through a mystic rite known as "de-gaussing" it. This consists of waving a large ring-shaped coil, about 18 inches in diameter, plugged into the mains, before the face of the tube, genuflecting and backing away the while. Appropriate incantations are chanted throughout this process. The coil is then unplugged, and the rites continue. Correctly done, this enables the attainment of a pure red screen. The red is turned off, and the procedure repeated for blue and green.

Now, the fun begins: convergence. A dot is selected in the centre, and it is "converged," to make a white dot; all three colours must be perfectly overlapped before this will happen. There is a total of four adjustments needed for this: for the blue, a small magnet on the neck of the tube is moved to move the dot sidewise, and the control on the front moves it up and down. The same control for red moves the red dot from 2 o'clock to 7 o'clock: the green dot moves from 10 o'clock to about 4 o'clock. The idea is to find a combination setting which will zero all dots in at a given location! At least fifteen adjustments were provided to accomplish this: vertical and horizontal static convergence, vertical and horizontal dynamic convergence, and vertical "tilt" for each colour: the last named are to correct any bowing in the lines of dots and to enable convergence to be achieved over the entire screen. Adjustment of these controls, I learned, must follow the proper order: failure to do this will upset the whole process and require repeating it from the beginning. (How did I learn this? *Please!*)

The end result of the procedure, after much patient coaching from Gene, was a pattern which was converged over almost the entire area of the screen, with the exception of about eight or ten dots at the corners. Gene assured me that this was very good, and that these would never be noticed in the picture. (This took place a year ago: since then, with perfection of techniques and adjustments, I've seen screens 100% converged!)

## Black and White Check

Now, we gave it the acid test; we tuned in a picture! In black and white, of course. Incidentally, this set was connected to a community-antenna system, and one of the things we wanted to check was the ability of the system's amplifiers to carry the colour signals, without clipping colour burst, etc., which they did, perfectly. The black and white picture was perfect. In fact, it appeared to have much better detail than that seen on a B. & W. set nearby. One could view it from a much closer distance, and get a better picture. This was due to the shadow mask inside the colour c.r.t., which broke up the scanning line structure and gave the picture the appearance of a newspaper halftone print, with its multitude of tiny dots.

This all took place in the morning: not until afternoon would we be able to view a colour programme. NBC was running "Howdy-Doody" every afternoon, between 3 and 4 p.m., in full colour. Gene had to leave as he was on his way to an appointment with another hopeful dealer, so he wished us well, and departed, with a few final guffaws at my attempts to converge. Eagerly we awaited the start of the programme. After the inevitable commercials, the familiar kaleidoscope

pattern was seen: this time in colour. But what colours! Instead of the bright rainbow we had expected, they were all washed out, pale and wan looking! We twiddled the various operating controls, with no results, no good ones, that is: the picture retained its weak pastel tones! The signal strength was measured and found to be around 1,000 microvolts: no trouble there, still pastels.

The next day we made further checks. The set still made beautiful B. & W. pictures, but once again the familiar pastels met our eyes. This time there was a great difference, however. The day before, the colours had at least "stayed put"; today, great waves of colour washed back and forth across the face of the tube! Red, green, blue; they waved back and forth like a demented rainbow, resulting in a very picturesque display, but hardly the one intended! Repeated adjustments of the controls had no effect. In desperation we tried to call Gene on the telephone, but he had vanished: no one knew where he was, and they didn't expect him back to his home until the last of the week!

### Chromatic Climax

Many alternatives were discussed, including suicide, without result. A careful study of the instruction sheet gave us no help. A glum group of technicians and salesmen watched the remainder of the show in a grim silence, broken only near the close of the show when a fat-faced trumpet player, in a close-up, puffed out his cheeks and blew a mighty blast on a final high note: as he did, his face turned a brilliant purple! It stayed purple until he took the horn from his lips, when it turned a pale blue! This wound up an otherwise dismal performance on a jovial note, and most of the audience departed, leaving the community-antenna technician and myself to further study of the situation.

Another colour show, a short 15-minute musical affair, follow the first. This displayed the same symptoms. We watched it for a few minutes, and then turned to each other and said simultaneously, "Let's try another station!" Fortunately, we had another NBC station on the cable system; one which had been included as a "standby," which was so far away that the signals were usually too weak and snowy to watch. Tuning the set to this station, we watched open-mouthed as the colours suddenly snapped into place with an almost audible "click"! Faces once again became flesh-coloured: dresses were red or green, hair lost its magenta tinge and became brown, etc. The salesmen came running from the back of the store, wanting to know what we were screaming about. We showed them. Turning back to the original station the colours once again wandered; on the weaker station they locked perfectly into place! With this as a clue, we came to the conclusion that the colour bursts were being clipped from the signal at the transmitter! This left us the colour, but no colour sync information, hence the wandering!

With this off our mind, we were free, the next day, to pursue our original problem: Why the pastels? No audience this time. The salesmen had abandoned all hope and disappeared, leaving only two puzzled technicians. Halfway through the show, I decided to attempt another adjustment of the much-adjusted controls, and reached for the "Chroma" knob. Watching the picture, I gave it a slight turn. The scene being televised was brightly coloured, or

should have been: gay drapes and costumes abounded, and the whole thing should have been a riot of colour; instead they were all pale and washed out. Suddenly as I turned the control, they leaped into vivid life: reds glowed, blues and greens became deep and rich, and the whole thing came up to the colour standard of a Technicolor movie!

Amid loud shouts of "Hey! Whadja do?" "Boy! Looka that, willya?" and similar exclamations, I investigated. Fortunately, my hand had frozen to the knob, and I discovered that I had turned the *brightness* control, instead of the "Chroma"! Further investigation revealed the horrifying truth: we had simply had the brightness turned up to maximum all the time! This gave our colour picture the same aspect as a black and white under the same conditions: it was just washed out! A few experiments with brightness and contrast controls showed us their proper settings, and the pictures we got were simply beautiful!

As a result of these experiences, we have come to this conclusion: the installing technician is the key man in the success or failure of any colour TV installation. If this worthy has the proper equipment and the "know-how" to use it, and the humility to read and heed the manufacturers' instructions, he will be able to obtain first-class colour pictures! The "know-it-all" type, who assumes that all sets have been constructed by a group of morons far below his technical level, and that he can make setup adjustments alone, using his own version of the procedure, is in for a rude awakening!

One dealer in another city told us that he'd had a new colour set which worked perfectly when unpacked: no adjustment at all! This happy state continued until his serviceman decided to check the convergence adjustments, using only a signal for reference; no dot generator! Ever since then, he moaned, everybody's had rainbows "round their shoulders"!

### Ready to Go

The practising TV technician's biggest problem, right now, outside of acquiring the extra cash to buy colour TV test equipment, is the lack of material to practice on! Although colour TV has taken hold to some extent in the larger cities, it is still a case of "few and far between" in the smaller towns, such as ours. In fact, here we have only two colour TV sets, at the moment: both are still on the dealers' floors! This is caused, of course, by one simple fact: the price! Although colour sets have been reduced tremendously during the past two years, from RCA's beginning with a 15-incher at \$15,000 down to the latest production of 21-inch sets listing around \$450 they are still away out of reach of the average TV buyer, and most especially the mass market. Until colour circuits are simplified enough to enable a price reduction to about \$300 we do not look for any drastic increase in colour-TV density! (The preceding statement is entirely the writer's own personal opinion, and is entirely uncluttered by such things as facts, etc.!)

One optimistic note is seen in recent articles in radio and TV magazines, detailing new and simpler circuits for colour matrixing, new colour c.r.t.s, such as Philco's Apple tube, the Lawrence Chromatron now under investigation by Dumont, and others. The last two named are single-gun tubes, and offer

the possibility of simpler convergence adjustments. (Speed the day!) These developments may bring the price down, by allowing elimination of many special tubes now necessary, and bring on an upturn in sales.

The broadcasters are doing everything they can to assist in this project. All of the major networks, and especially NBC, are programming many more hours of colour shows than ever before. NBC stations in this area send out to TV servicemen and dealers a colour TV programme schedule, listing all shows in colour for the coming month. Last year this did not fill a single sheet: this year it fills three sheets, and many of the shows listed are on every day under a single listing, such as NBC's Matinee Theatre, in colour every afternoon from 1 to 2 p.m. However, the future remains doubtful, as far as any drastic upturn in colour TV sales is concerned, especially in this area. We await with optimism new developments, and do whatever we can to further the cause.

So, in conclusion, as far as the average American

TV serviceman is concerned, with colour, he regards it mainly as he did black and white TV: as a challenge to his technical skill. He expects no trouble from the sets themselves. (Note: I did *not* say he was going to *have* no trouble; I merely said that he *expected* no trouble!) Just as before, he's in for troubles, and plenty of 'em! He's facing the same situation right now that he did with the B. & W.s. He didn't expect much trouble from those, either. "After all, they're just like radios, only bigger!" (The bitter laughter you hear in the background is from the author and his colleagues!)

However, he has a massive body of help available, in the form of literature, technical information, training courses, manufacturers' literature and schools, and the like, so the chances are he'll be able to attain a degree of proficiency in this, as he did in black and white TV, radio, "hi-fi," and all of the other subjects he's been called upon to cope with. He'll still have plenty of problems, but as the costers sing in the Broadway version of "My Fair Lady," "With a little bit of luck he'll get by!"

## Unconventional Communications Receiver

Continuously Variable Crystal Control; Wide-band Coverage Without Waveband Switching

**V**ARIOUS systems have been devised to apply the stability of crystal control to wideband communications receivers, the most common being a multiplicity of crystals used in various combinations. These involve complicated switching systems and often restrict the equipment to operation on a number of fixed spot frequencies.

An attractive system which forms the basis of the design of a new communications receiver, Type RA17, being produced by Rascal Engineering Ltd., of Bracknell, Berks, makes use of the harmonic spectrum of a single crystal to cover a tuning range of 500 kc/s to 30 Mc/s without gaps of any kind and without any of the conventional forms of waveband switching.

The block schematic diagram shows the basic arrangement, from which it will be seen that the received signal is first amplified by an aperiodic r.f. amplifier covering 0 to 30 Mc/s, then mixed with the output of a variable oscillator covering 40.5 to 69.5 Mc/s in a single range to produce an input to the first i.f. amplifier of 40 Mc/s. This amplifier has a bandwidth of 1.3 Mc/s. At the same time part of the output of the local oscillator is combined in a second mixer with the harmonics, up to the 32nd, of a 1-Mc/s crystal-controlled oscillator and a second i.f. output at 37.5 Mc/s appears at the output of a tuned filter having a bandwidth of  $\pm 150$  kc/s. In order to obtain the 37.5 Mc/s i.f. the 40.5 to 69.5 Mc/s oscillator (Mc/s

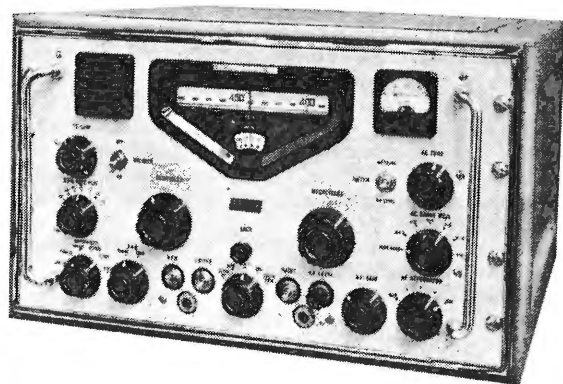

scale) must be set to within 500 kc/s,  $\pm 150$  kc/s tolerance, of a harmonic of the crystal-controlled oscillator. Any change can only be steps of 1 Mc/s, so that for every setting of the variable oscillator a 1-Mc/s panorama of signals, derived from the first mixer, is presented to the 40-Mc/s i.f. amplifier. Its bandwidth must be, therefore, 1.3 Mc/s wide in order to accommodate this band of signals, plus the 300-kc/s tolerance in the setting of the oscillator brought about by the 300-kc/s bandwidth of the 37.5-Mc/s i.f. filter.

The 37.5-Mc/s i.f. and the 1-Mc/s panorama of signals from the 40-Mc/s i.f. amplifier are then combined in a third mixer which gives a "panoramic" output from 2 to 3 Mc/s and this is passed to a conventional form of superheterodyne receiver (interpolation receiver) which selects the wanted signal from the 1-Mc/s panoramic input. Its tuning is linked with the long film scale calibrated in kilocycles.

It will be apparent that with so many r.f. oscillators of one kind or another very great care has had to be given to the screening and filtering of these circuits in order to eliminate set-generated whistles and the effectiveness of this filtering was apparent by the almost entire absence of whistles in the receiver demonstrated to *Wireless World*.

Tuning is effected by two operations, both quite simple. First the megacycle scale (40.5 to 69.5 Mc/s oscillator) is adjusted to the nearest megacycle of the signal frequency, then the fractional part of the frequency is set up on the horizontal film scale (the 2 to 3 Mc/s receiver tuning), which is 60 in long and provides a setting accuracy of 200 c/s. Any drift in the local oscillator is of no consequence as it cancels itself out in the third mixer and the setting of the megacycle scale is, therefore, not critical. By using an unusually high first i.f. and a low-pass filter passing 0 to 30 Mc/s in the r.f. amplifier, conventional tuned r.f. circuits have been dispensed with.

The complete absence of mechanical waveband switching in the signal and oscillator circuits contributes significantly to the re-setting accuracy and stability of the receiver over long and short periods of time. To assist further in accurately setting the receiver to a particular frequency there is a built-in 100-kc/s pulse calibrator with pulses derived from the main 1-Mc/s crystal oscillator.

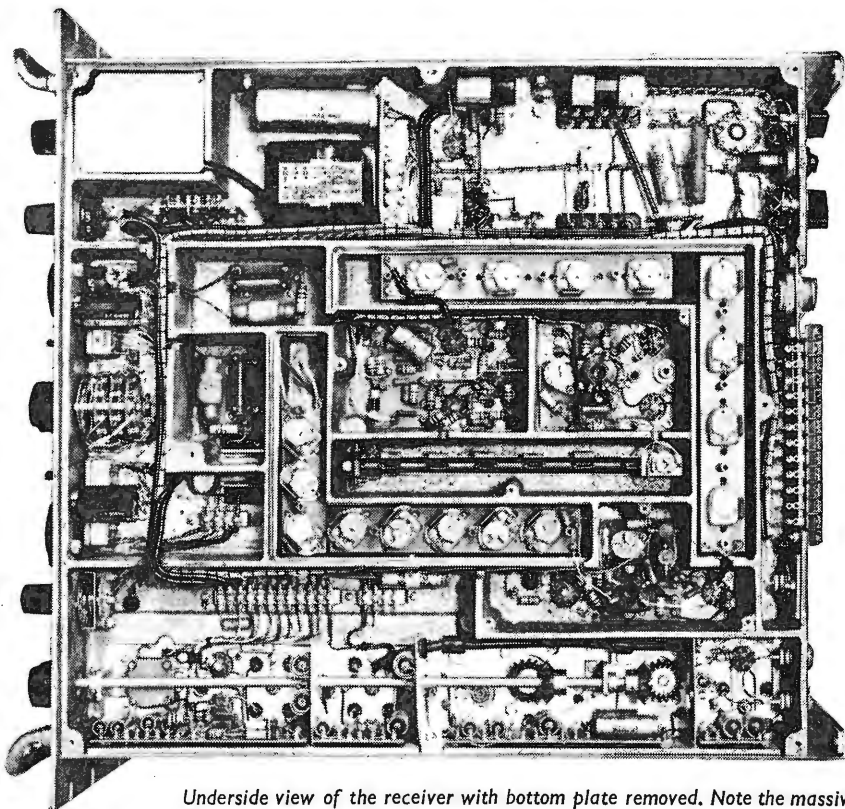

Underside view of the receiver with bottom plate removed. Note the massive die-cast chassis divided into several fully-screened compartments.

This supplies calibration "pips" at every 100 kc/s of the film scale.

A calibrated and stable BFO, adjustable to  $\pm 3$  kc/s is included, together with a tone control, a variable selectivity control giving alternative bandwidths of 100 c/s, 350 c/s, 750 c/s, 1.2 kc/s, 3 kc/s and 8 kc/s respectively, noise limiter and "s" meter.

The dimensions of the set are 19 in wide, 10½ in high and 20 in deep; the weight is 56 lb without case and 79 lb in case. The power consumption is about 90 watts from the a.c. supply mains.

Block schematic diagram of the Racal RA17 receiver.

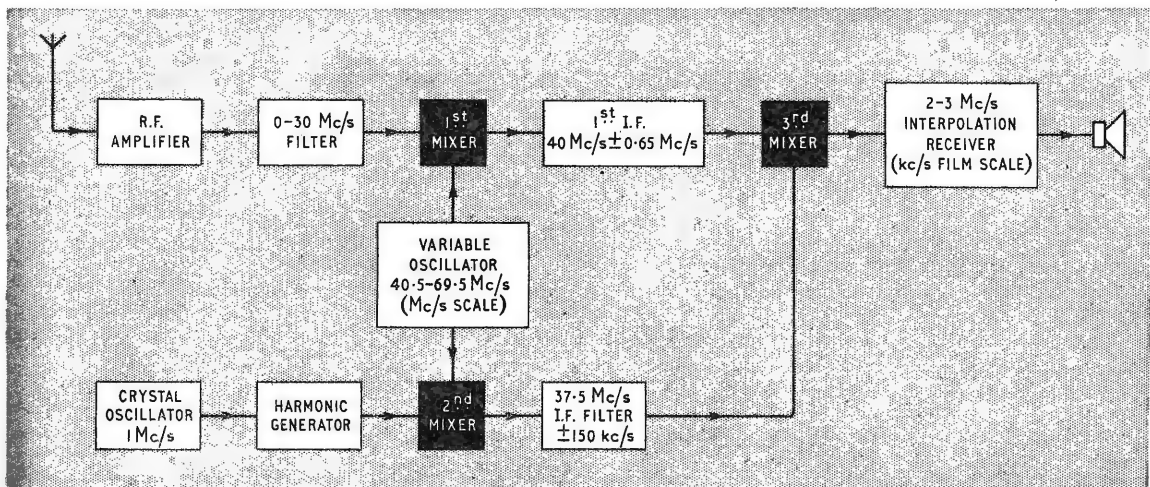
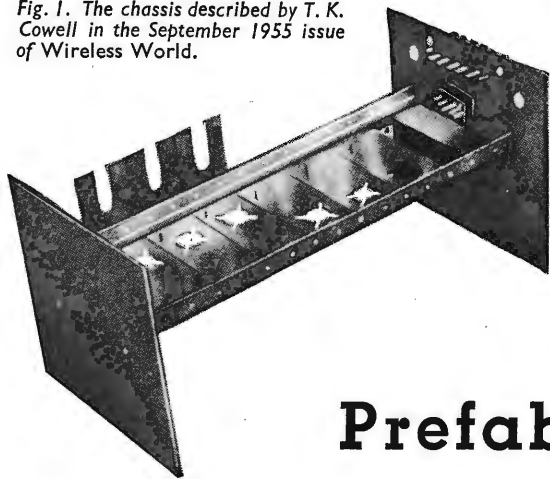

Fig. 1. The chassis described by T. K. Cowell in the September 1955 issue of *Wireless World*.



DESIGN COMBINING SIMPLICITY  
WITH VERSATILITY

By D. M. NEALE\*, B.Sc., A.M.I.E.E.

## Prefabricated Chassis

**I**N the September 1955 issue of *Wireless World*, T. K. Cowell described a chassis (Fig. 1) for experimental and development work. It was assembled from a number of standard parts so designed that arrangements could be chosen meeting most practical requirements. The system filled a need which had previously been felt in our physics research laboratory and it was disappointing to find that the parts were not being marketed.

Cowell's system was based on the use of eight

standard parts. It is accordingly uneconomic for one, relatively small, user to have these parts made to order since the cost of tooling up is prohibitive. The writer has therefore developed the idea further to provide a system more flexible than the original yet requiring only one specially produced component.

It will be seen from Fig. 1 that Cowell's system consisted of valveholder plates and potentiometer brackets bolted to angle-brass runners. These runners were supported at either end by angle brackets bolted to end-plates of which there were four different types. In the modified system, illustrated in Fig. 2, "Meccano" angle girders are used for the runners and angle brackets. These components are already mass produced and readily available. It is therefore unlikely that anything more economical or more convenient can be devised. In fact, the retail price of the finished Meccano parts is about half that of the raw material for parts made in brass. In the original

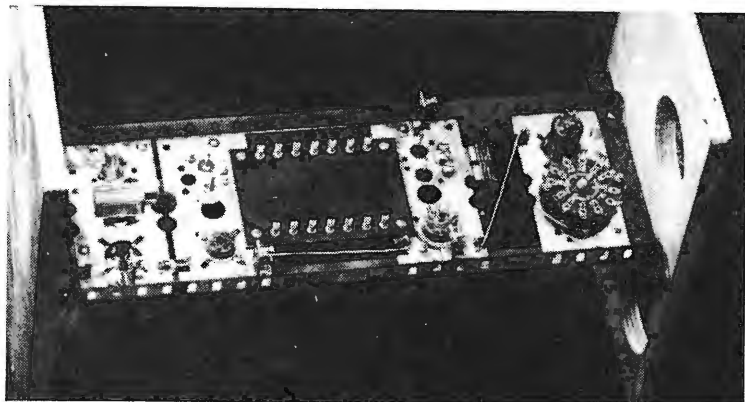
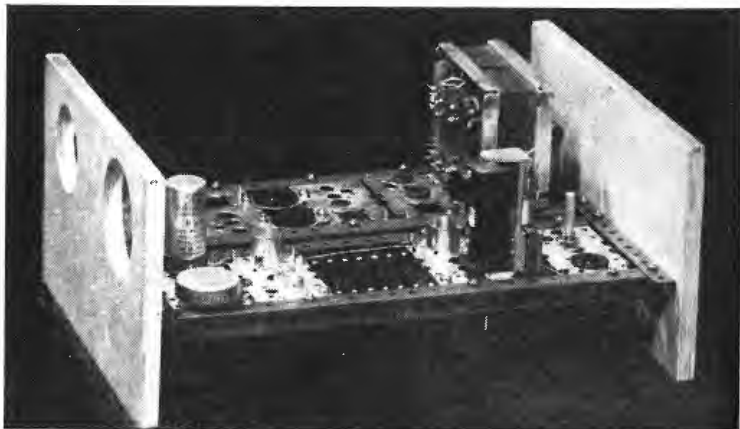

Fig. 2. Underside view of a  $12\frac{1}{2}$  in  $\times$  4 in chassis using the new design of plates, Meccano angle girders and wooden end-boards.

Fig. 3. Top view of a chassis assembled with two  $12\frac{1}{2}$  in  $\times$  4 in units using the same wooden end-boards as shown in Fig. 2 but with the long sides horizontal.



\*Ilford Limited.



system, the runners were drilled and tapped, but a further economy has been effected by using  $\frac{1}{4}$ -in 4-B.A. bolts and nuts in the Meccano perforations.

By using wooden end-boards, the need for four specially produced metal end-plates was eliminated. Only one size is used and this may be produced quickly by unskilled labour. Holes may be cut in some of the end-boards to accommodate 2in and 2½in instruments, but no other components are as a rule mounted on these boards. Figs. 2 and 3 show that the same 10in × 6in end-boards may conveniently be used to support either one or two 12½in × 4in chassis assemblies.

The essence of the new system is a new valveholder plate (Fig. 4) designed to suit the  $\frac{1}{2}$ -in hole spacing of the Meccano runners. So far as possible, this plate has been made to accommodate all the more common types of component, whilst at the same time keeping to a minimum the number of holes to be formed in the plate. The new type of plate will accept a B7G or B9A valveholder with retaining can and/or a carbon or wirewound potentiometer, several stand-off pillars, rubber grommets, a wafer switch, a toggle switch, two coaxial sockets, a pilot lampholder, an electrolytic capacitor or a Type 3,000 Post Office relay. Fig. 5 shows clearly how provision has been made for various locating spigots and also how rubber grommets are held by semi-circular cut-outs in adjacent plates. Other components may be mounted between one valveholder plate and the next, or between the valveholder plate at one end of the chassis and the cross-bearer supporting the runners. In this way, it is possible to mount terminal boards, Jones plugs and sockets and the larger types of valveholder and electrolytic capacitor without drilling any further holes in the valveholder plates.

Since the potentiometers are mounted in the valveholder plates, rather than at right angles to them, it is a simple matter to transfer successful "bread-board" circuits to rack mounting when required. It is necessary only to remove four nuts and bolts to detach the wooden end-plates and Meccano bearers from the assembled 12½in × 4in chassis. Four of these chassis may be mounted side by side across the width of a 19-in rack with a  $\frac{1}{2}$ -in space between each. Standard 18½-in Meccano angle girders may be used as horizontal bearers, but it then becomes

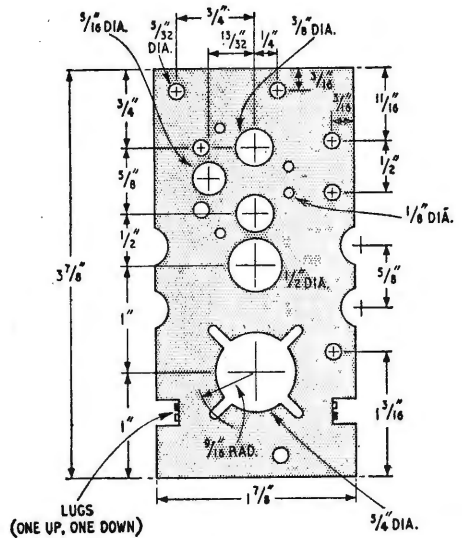

Fig. 4. Dimensions and drilling details of the new valveholder plate.

necessary to drill and tap the rack at non-standard spacings. However, not many such holes are required and these do not conflict with standard hole positions.

Valveholder plates may be made in 22 s.w.g. bright mild steel, electro-tinned after stamping. A cadmium finish may also be used provided it is not passivated. The electro-tinned finish simplifies soldering to the earthing tags on the plates. It is, of course, essential to bond all plates together by a tinned copper wire joining the earthing tags since the enamel finish of the Meccano runners makes earthing through the securing bolts uncertain. It was expected that earthing troubles might arise with r.f. circuits, but a 7-stage video amplifier with 2 Mc/s bandwidth has given no trouble at all.

The above design is proving a very satisfactory

Fig. 5. Showing how components can be mounted between valveholder plates and how rubber grommets are accommodated in semi-circular cut-outs.

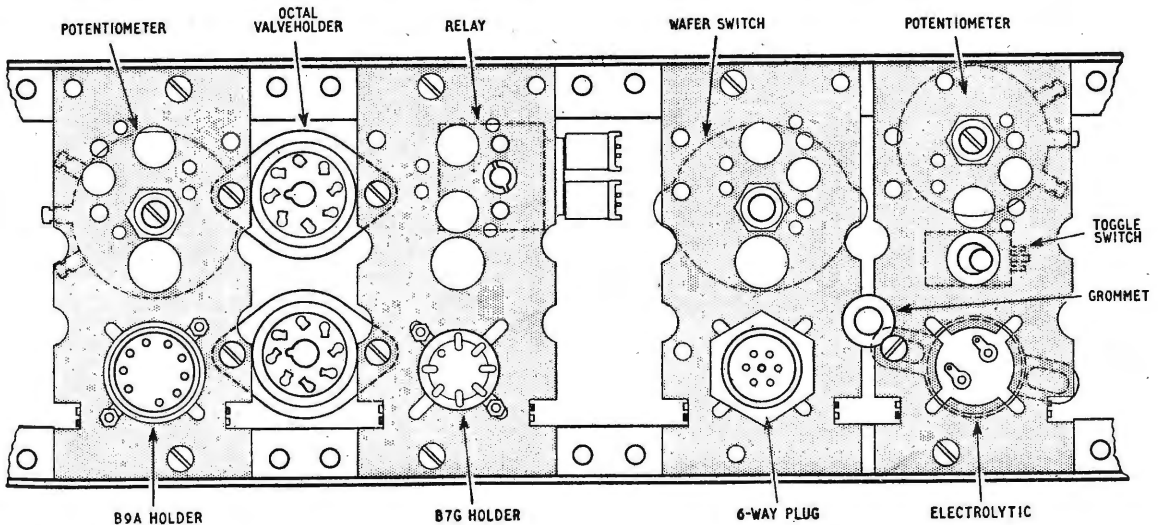





# POTENTIAL — MAP READING IS A GREAT HELP

By "CATHODE RAY"

IT is customary for the people who unravel the intricacies of semi-conductor theory to illustrate their remarks with diagrams showing the variations of electrical potential in the material. Fig. 1, for example. This represents a p-n-p junction transistor, and it is pointed out (though probably in more refined language) that if the "holes" shown reposing on the emitter shelf are jerked up the slight hill to the base they are very likely to topple over the potential precipice on the other side and land on the collector.

Assuming it is clear to all why the potential diagram should have this particular shape, fair enough. But is it safe to assume this? If the relative heights of the various parts of the graph corresponded to the voltages imposed from without on the electrodes corresponding to those parts, all is well. So far as the collector is concerned, all is well, for its depressed potential corresponds to the relatively large negative voltage applied by a battery. But on the same principle the base potential ought to be slightly lower than that of the emitter, to correspond with the small negative bias applied.

Presumably the instructor will have already dealt with this anomaly by some preliminary work on the simple p-n junction, in which he may well

people who talk about potential would be unable to say what it means?

There are various textbook definitions; for example: "Potential is the quantity whose space rate of change in any direction is the field strength in that direction." That is delightful for people who thrive on textbook definitions, but what does it mean in terms that can easily be visualized?

## Potential, Height and Energy

One thing we can hardly have failed to notice at a very early age is that where differences of height occur between two places there is a tendency for things to move from the higher place to the lower. Further observation shows that the greater the gradient between the two places the greater the tendency. This tendency has been named gravitation. To sound more scientific we can call the tendency the force due to a gravitational field—the one in which we happen to be situated. Another name for gradient is rate of change of height. So if we look again at the textbook definition we discover that it defines what we usually call height. Height, in fact, is the particular kind of potential when the field is a gravitational one. A gravitational field manifests itself by the force it exerts on the mass of objects. An electric field manifests itself by the force it exerts on the electrical charge of objects. But whereas electric potential (which is the one we are supposed to be discussing) is difficult to visualize, gravitational potential in the guise of height is familiar to all. No wonder, then, that it is the favourite analogue for potential. A particularly attractive feature of the analogy is that diagrams like Fig. 1 become more than mere graphs; they are also drawings of working models whose mechanical performance gives quite a good idea of the electrical performance of the thing repre-

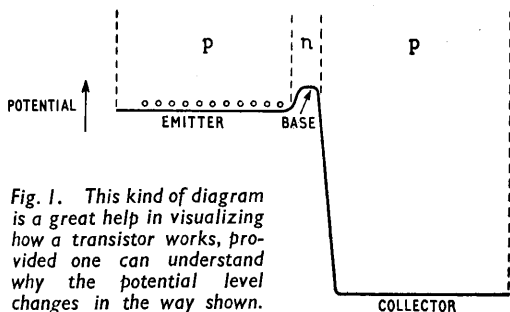

Fig. 1. This kind of diagram is a great help in visualizing how a transistor works, provided one can understand why the potential level changes in the way shown.

have exhibited something like Fig. 2. Here it is supposed that no batteries are connected, the potential changes shown below being a result of the distribution of charges shown above. Now this is the point where I suspect the assumption of obviousness often comes unstuck. I feel that those whose studies have tended towards the practical rather than the theoretical are likely to associate potentials with applied voltages and are not particularly enlightened by potential diagrams derived from vague charges inside a chunk of material. It was for this reason that I carefully avoided potential diagrams when on this semi-conductor subject just a year ago.

But such diagrams do appear, and if it is true that some of us are not too clear how they are arrived at, then it is time we went back to first principles to find out. Is it unkind to suggest that a lot of

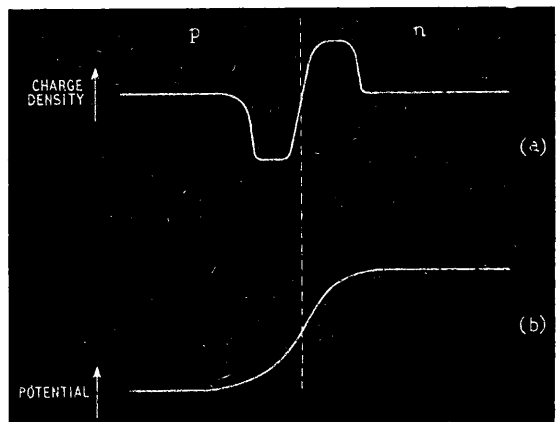

Fig. 2. This is the usual explanation, but is it clear why (b) follows from (a)?

sented. (Like most attractive things, however, this analogy can lead one astray if one doesn't know where to stop.)

If the dimension along the arrow in Fig. 1 represents height, the diagram is a vertical section of the gravitational analogue of the transistor. In the same way Fig. 3(a) is a vertical section across a tract of country. In this form, the information is limited to a single line on the ground, so it is more usual to transfer it to the horizontal plane as shown at (b), forming a contour map. Of course, this one vertical section locates only a row of points along AB; to draw the contour lines it is necessary to plot the heights at many more places. Alternatively, Fig. 3 shows how a contour map can be used to construct a vertical section along any line. It is the same with potentials; given one form of diagram, the other can be derived.

Now although a scale of height is shown in Fig. 3(a), what usually matters most is the relative height. The appearance of this piece of country, and the behaviour of loose objects on it, would not be affected if all the figures in the scale were increased or decreased by some fixed amount. There is really no such thing as absolute height; the figures usually specified are heights relative to mean sea level. In the same way there are only relative potentials. Unless the contrary is stated, "earth" is the "mean sea level" in the electrical world.

The meaning of a contour line is that all points on it are at the same height. It could be called an "equi-height line." Analogous to it on a potential map is an equipotential line. As Fig. 3 illustrates, steepness of gradient can be judged from a map by closeness of contour line spacing. So without looking at (a) we can easily see that there would be a stronger tendency to fall down the right-hand slope of the hill than the left. What we may actually have done by now, however, is to have fallen into a trap. How did we reckon the gradient?

## Rolling Stones

The usual procedure is to measure the distance on the map between two contour lines. Take the points  $x$  and  $y$  on Fig. 3(b). Suppose the distance scale shows them to be 200ft apart. Then, as  $x$  is 100ft higher than  $y$ , the gradient is said to average 1 in 2, or  $\frac{1}{2}$ . If somewhere two contour lines were found to touch, the gradient there would be 1 in 0, which is infinity. According to our textbook definition, that ought to mean an infinitely large gravitational force! It would certainly mean an infinitely large electric force if two equipotential lines touched. But we know in fact that even at a vertical precipice, where the gradient is (according to usual reckoning) 1 in 0, the force on a body is no more than equal to its weight. Where is the catch?

No doubt you have already spotted it—the practice of reckoning land gradient in terms of height difference per *horizontal* distance (because that is what one can measure on the map). In applying the textbook definition to a hillside we tacitly assumed that the gravitational field strength is reckoned along the surface of the ground, because that is the only place where stones, etc., can roll; so for that purpose gradient ought to be reckoned as difference of height per distance *along that surface*. The maximum is therefore 1 in 1, or the full vertical gravitational pull. The operative word in the definition is "space rate

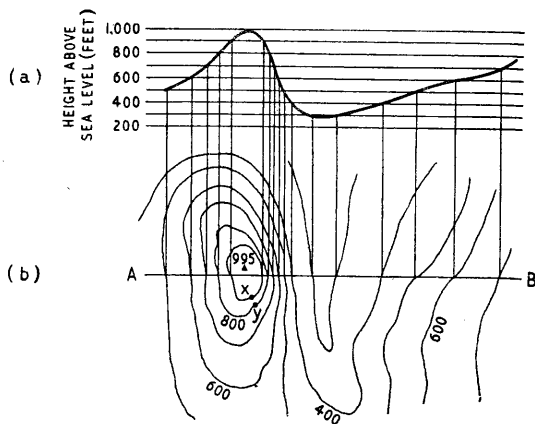

Fig. 3. Vertical section and contour map of a hill. It would be strictly correct to refer to the height scale as a potential scale.

of change." Our interest in electric force is not usually limited to the two dimensions of a surface, but may occupy three-dimensional space. So electric contour maps are not necessarily based on a horizontal plane.

This shows how careful one must be not to swallow an analogy whole without making sure that there are no differences in custom regarding method of reckoning.

An advantage of a contour map over a vertical section is that it shows not only the amount of gravitational pull (when correctly reckoned!) but also its direction. Obviously the gravitational force is a maximum in the direction of steepest downhill gradient. And the steepest gradient between two parallel contour lines is at right angles to them, because that gives the shortest distance from one level to the other. So a ball will tend to roll in that direction, along what we might call a line of gravitational force. In the same way, the so-called lines of electric force are everywhere at right angles to the equipotential lines.

We mustn't jump to the conclusion that the lines of force (gravitational or electric) are the paths that would actually be taken by a freely rolling ball or a freely moving charge. Fig. 4 shows a succession of contour lines, and we can plot a line of force beginning at A by drawing it at right angles to them (and to all the intermediate ones, not shown but estimated). It arrives at B. But a ball released at A would depart from this line directly it began to turn the corner, because its own inertia would tend to carry it on in a straight line (Newton's first law of motion). The ball's path—probably something like the dotted line—would be determined by the resultant of its movement in the direction of the line of force and its previously acquired movement in another direction. Roughly the same is true of a charged body in an electric field; even an electron has some inertia, minute though it is. But here there is another slight flaw in the analogy, for the ball rolling under the influence of gravity is rather a special case, in that the gravitational force tending to deflect it from its original direction is proportional to its mass and therefore to its inertia, so that (apart from secondary effects such as friction) balls of every weight would

follow the same path\*. Charged bodies are not so; the force brought to bear on them by an electric field is proportional to their charge, which is quite a different thing from their mass or inertia. This distinction is not merely academic; it has an important bearing on the design of the domestic television tube. When an electron is knocked off an atom, it and the damaged atom (or *ion*) have equal though opposite electric charges, so have equal forces acting on them in a given electric field. But the mass of the ion is enormously greater than that of the electron, so the field deflects the ion far less. Advantage is taken of this fact in devising ion traps to prevent negative ions from bombarding the screen.

A very important part of the subject of potential concerns work and energy. Rolling a ball or anything else uphill is work in the strictly technical sense, and can only be done at the cost of energy. If a 10-lb weight is raised 50 feet, measured vertically, 500 ft-lbs of work have to be done (not counting friction); and the weight gains 500 ft-lbs in potential energy. Its potential is increased by 50 feet. So another way of defining height could be as the amount of work that had to be done on a standard weight—say 1 lb—in order to lift it from the lower to the upper level.

If a weight is allowed to go downhill, its potential energy is (neglecting friction) converted into kinetic energy—energy of motion—which is capable of doing work. For instance, it could carry the weight some way up a hill. So alternatively height could be defined as the amount of energy acquired by a standard weight in falling from the upper level to the lower. This amount could be judged by the velocity it has acquired.

It happens that height can usually be much more conveniently and accurately measured as vertical distance. But one cannot measure difference of potential in any such simple and direct way, so reckoning it in terms of work is of practical as well as

theoretical importance. In fact, potential is commonly defined as the amount of work required to transport unit charge from one place to the other—a definition apparently quite different from the one quoted at the beginning, but amounting to the same thing.

Of course it is necessary to be consistent with the units. If you want the potential difference to be in volts, the unit charge must be taken from the same set of units, viz., one coulomb, and the work must be reckoned in joules (= watt-seconds). In electronics one is so often concerned with the very minute amount of work required to push a charge of one electron up a potential hill reckoned in volts that a semi-official unit of work or energy—the electron-volt (eV)—is commonly used. It is about  $1.6 \times 10^{-19}$  joule.

It is also necessary to get the signs right. Saying the difference in height between A and B is 50 feet is not much help unless one knows whether A is higher or lower than B. If work has to be done on the standard weight to move it from A to B, that implies at once that B is higher than A. But it is really meaningless to ask which of two points has the higher electric potential because, in relation to potential, "height" is only metaphorical. It has however been generally agreed to describe the potential at A as higher than at B (relative to B) A has a surplus charge of the kind arbitrarily called positive. (This is the same thing as B having a surplus of the other kind of charge, called negative). Now it is an experimental fact that charges of the same kind repel one another, so one of them has to have work done on it to make it move nearer the other. It follows that if a positive charge needs an external effort to make it go in a certain direction, then that direction is towards a higher potential. The natural tendency of a positive charge, then, is to run "downhill," so it is the analogue of the rolling stone on a hillside. A negative charge, on the contrary, tends to move "uphill" towards points of higher potential.

For the purpose of this explanation I attributed the high potential at A to a positive charge there, but it is not necessary to have any charges at either point between which there is a difference of potential. In the arrangement shown in Fig. 5(a) the battery transfers electrons from plate  $P_1$  to  $P_2$ , charging  $P_2$  negatively and  $P_1$  positively. This establishes a difference of potential (equal to the voltage of the battery) between the plates, and there will be a potential gradient from one to the other, A being at a higher potential than B; see Fig. 5(b). An electron in the space between them would tend to move towards A and would have to be forced to move towards B. An analogue of this could be constructed of a large sheet of thin rubber stretched on a horizontal frame, with a horizontal rod to represent  $P_1$  pushed up from below to raise the rubber into a ridge, and another one ( $P_2$ ) pushing it down. Bearing balls could represent loose positive charges. If the space beneath the rubber were filled with liquid, electrons could be represented by small air bubbles, which would tend to run towards  $P_1$ .

All this may be simply underlining what I began by assuming everyone understood—the potential patterns due to batteries and other sources of volts. But when tackling the potential gradients inside semi-conductors, next month, it will be an advantage to have some definite ideas about the meaning of the word "potential."

\* It was this curious fact that led Einstein to his General Theory of Relativity.

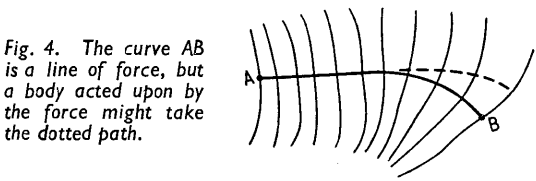

Fig. 4. The curve AB is a line of force, but a body acted upon by the force might take the dotted path.

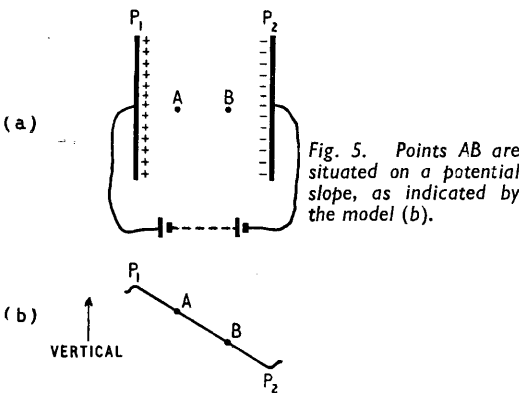

Fig. 5. Points AB are situated on a potential slope, as indicated by the model (b).

# Doppler Navaid for Civil Aircraft

Self-contained Air Navigational System Entirely Independent of Ground Station Co-operation

**M**ILITARY aircraft of the Royal Air Force have been using the Marconi Doppler Navigator for the past three years, but so far nothing quite comparable to it has been available for civil aircraft. All the existing airborne radio nav aids require the co-operation of one or more ground stations and failing this navigation in the air hitherto had to rely on old-fashioned systems. More important than this the pilots of civil aircraft flying to-day have no accurate knowledge of the actual ground speed, drift or prevailing wind velocity.

These points serve to underline the importance of the new Doppler Navigator, Type AD2300, specially designed for commercial aircraft and recently introduced by Marconi's Wireless Telegraph Company. The equipment operates as a self-contained system in the 8,000-Mc/s band and is entirely independent of any ground station.

The AD2300 provides the airline pilot with accurate indication of ground speed, drift-angle and distance flown, and used in conjunction with a computer, gives instantaneous and continuous information of the aircraft's immediate position in latitude and longitude, wind direction and wind speed. The distance to go along a "leg" of a pre-determined flight plan, or the distance to fly along a composite track to reach a destination, and also more accurate computation of ETA (expected time of arrival), than hitherto, comprise some, but by no means all, of the navigational information available with this new nav aid.

## Theory of Operation

The full equipment comprises an aerial system, a transmitter-receiver, a tracking unit, computer and display unit. The system is based on the phenomenon of the displacement in frequency which occurs at the receiving position when the transmitter and receiver are in relative motion to a fixed point of reflection of the waves. The basic principles were described in *Wireless World* recently.\* Two c.w. beams are radiated from the aerial one projecting forward and the other backward and both are depressed towards the ground. A small amount of the radiated energy is returned, by ground reflection, to the aircraft where analysis is made of the difference in frequency existing between the transmitted and received waves. This difference is directly related to the speed of the aircraft relative to the ground.

By displacing one beam to starboard and the other to port, and alternately switching their positions, the drift angle of the aircraft is found by comparing the Doppler frequency when the forward beam is displaced to starboard and the backward beam displaced to port, to the frequency derived when the beam positions are reversed. The aerial is then rotated until the two frequencies are equal and it is then aligned along the aircraft track.

The aerial system comprises four slotted linear arrays lying parallel to one another in a directional horn assembly with the axis of the aerial horizontal. The forward and backward beams are obtained by feeding from each slotted unit in turn, two waveguides being used for transmission and two for reception. At the half-power points the beam width is  $3\frac{1}{2}^\circ$ . A sample of the transmitted signal is extracted in a directional coupler and mixed with the received signal.

## Airborne Computer

The transmitter and receiver units and their associated power supplies are housed in a single unpressurized case with cooling complying with the American ARINC standard. The carrier wave is generated by a klystron and the transmitter output is one watt. The output from the receiver is fed to the tracking unit, which contains the frequency measuring circuits for determination of ground speed and drift angle, a.g.c. and automatic search circuits. Frequency measuring is effected in a discriminator, where the Doppler signal is compared with the tone generated by a phonic wheel. The resultant frequency is used to control integrator and azimuth drive circuits, the former controlling the speed of the phonic-wheel motor and the latter a motor situated in the aerial system which rotates the aerial for drift-angle measurement. The phonic-wheel speed is a measurement of aircraft ground speed.

The resultant speed and drift information is fed to the computer, an electro-mechanical type using analogue methods for solution of the trigonometrical equations concerned in the navigational problem. Inputs of compass heading and true air speed are also fed to the computer.

The display is capable of considerable variation to suit individual requirements. It may be embodied in the computer, or if the only information required is ground speed, drift angle and distance flown, these can be displayed by a small indicator unit which will in such cases replace the computer unit.

The Marconi AD2300 operates over an altitude range of 150 ft to 50,000 ft, at ground speeds of 80 to 900 knots, at drift angles up to  $\pm 45^\circ$ , up to  $10^\circ$  climb or descent and up to  $20^\circ$  of bank. The equipment will function in steeper angles of climb, descent and bank than given, but the accuracy may be degraded slightly.

A pilot's left-right indicator for steering the aircraft on a desired rhumb line, or great-circle course, can be included, also information of distance to destination and visual indication when the end of a "leg" of a pre-determined course has been reached. In addition the left-right course indication is available as a signal for feeding into an auto-pilot.

All units are for standard ARINC rack mounting and all valves have American equivalents. The total weight, including aerial system and computer, is 130 lb.

\*" Airborne Doppler Navigation " by G. E. Beck, *Wireless World* May 1957, p. 225.

**Helical-Scan E.E.G.** display described by H. W. Shipton in Vol. 7, No. 2, of the *Proceedings of The Electro Physiological Technologists' Association* uses a number of small c.r. tubes to give a topographic presentation of brain potentials picked up simultaneously from various parts of the patient's head. In an earlier "electrotoposcope" the c.r. tubes had a p.p.i. type of rotating radial timebase, as shown in (b), a stationary pattern being obtained when the rotational speed of the timebase was related to the frequency of the e.e.g. signal. When, however, a photographic record was taken, the light

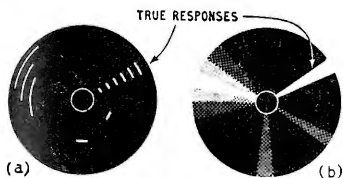

integration made it difficult to distinguish the true responses, related to the timebase rotation (at "2 o'clock"), from others of short duration (4 and 6 o'clock), and those formed by overlapping when a signal was drifting slowly round the tube (at about 9 o'clock). With the helical scan, however, which increases in diameter during the camera exposure, the different types of responses can be clearly distinguished, as shown at (a). Signals related to the rotational speed appear at the same bearing on successive sweeps but with changing radius. Where there is not an exact relationship, a progressive displacement occurs on successive sweeps from which an estimate of frequency can be made.

**Grown Infra-Red Crystals**, for use as windows, lenses and prisms in this not-quite-optical part of the electromagnetic spectrum, are now being produced on a commercial scale with a purity and crystalline perfection superior to that of the natural material. Hilger and Watts, for example, are growing rocksalt (sodium chloride) crystals about 8 inches in diameter by 4 inches thick from which optical components can be cut. The polished surfaces can be aluminized if necessary. Rocksalt is transparent over the wavelength range 0.2 to 15 microns, but potassium bromide crystals of similar size can be grown to extend this to about 26 microns and caesium bromide crystals to go up to 40 microns. Where the infra-red components have to be used in extremes of temperature or with rapid heating and cooling rates, silicon crystals offer distinct advantages. These are being grown by the American firm Texas Instruments with impurities of less than 1 part in  $10^8$ . A silicon component 3mm thick will transmit

# Technical Notebook

over 50% of the incident radiation between 1.3 and 9 microns, but transmissions greater than 90% can be achieved at particular wavelengths within this range by applying a low-reflection coating to the material.

**Information-Theory Servicing** of electronic equipment is discussed by R. B. Miller, J. D. Folley and P. R. Smith in D.S.I.R. unpublished report PB118038. Methods of fault diagnosis using the "half-split" technique for eliminating alternatives leads to a consideration of the relationship between fault-finding, information theory and probability data.

**New Storage Ferroelectric** called triglycine sulphate has the same kind of rectangular voltage hysteresis loop as the well-known barium titanate but with a much lower coercive field, allowing it to be switched from one state to the other with potentials of only about 20 volts. This means that transistors can be used for driving purposes. Discovered by B. T. Matthias of Bell Telephone Laboratories, the new material is stable chemically and does not decompose when exposed to moisture or to the atmosphere. Large single crystals can be grown quite easily (see picture), and a number of large-area slices can be cut from each crystal. Repeated switching does not cause any fatigue in this material, as it does in barium titanate, and a given area will retain a given polarization in-

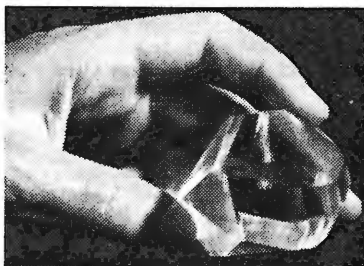

definitely without any deterioration. Although heating beyond 47°C (the Curie point) causes the material to lose its ferroelectric properties, these properties are regained in full when it is cooled. By replacing some of the hydrogen atoms with deuterium the Curie point can be raised to

60°C. Switching times of the order of 1-2  $\mu$ secs can easily be attained. A matrix store can be constructed with 30 or more electrodes to the inch evaporated on to each side of a thin slice of crystal. This means that 900 or more binary digits can be stored on a square inch of the material—a very compact form of storage compared with most other methods.

**Function Generator Tube** designed by L. S. Allard of G.E.C. Research Laboratories is a self-contained c.r.t. device which depends for its operation on the equal division of beam current between two target electrodes. Conventional c.r. tubes have been used as function generators in the past—the spot being made to follow the profile of an opaque mask stuck on the tube face—but these suffer from the disadvantages that the screen phosphor is very readily



burnt and that voltage fluctuations are introduced into the output by the granular structure of the screen. In the G.E.C. tube one of the two target electrodes is cut to give a profile of the required function while the other is a planar disc. As the electron beam is scanned across this assembly in the X direction it is constrained to follow the profile by a feedback voltage derived from the target electrodes, which is applied to the Y deflection plates so as to maintain the equal division of beam current between the electrodes. The voltage applied to the Y plates varies in accordance with the y ordinates of the profile electrode and so provides the required output.

**Fast Kerr Cell**, using nitrobenzene, is being developed as a light shutter to give extremely short light pulses of the order of micro-microseconds. Some parts of the work are described in D.S.I.R. unpublished report PB118714, by G. L. Clark, D. K. Holshouser and H. M. Von Foester.

**Square-Law Thermocouple.** — A method of compensating a thermocouple to make it accurately follow a square law was shown at the recent N.P.L. Open Day. By joining a platinum wire of high tempera-

ture coefficient of resistance in series with the thermocouple an opposite deviation can be added to that of the thermocouple. In this way power measurements to within 0.25% can be obtained.

**C.R.T. Chronograph** has been built for measuring and recording a large number of consecutive time intervals. The signals appear as lines on a c.r. tube raster and are recorded photographically. Circuitry and possible extensions are discussed in D.S.I.R. unpublished report PB114757 by H. G. McGuire and K. A. Yamakawa.

**Video Response Control**, equivalent to the tone control of a sound broadcast receiver, is used in a recent German television receiver, the Nord-

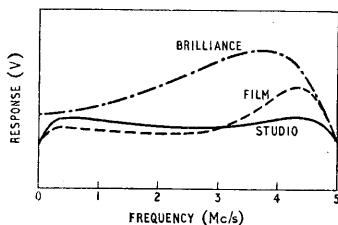

mende "Diplomat 58." Three conditions are available, "Studio," "Film" and "Brilliance," as shown in the accompanying sketch, and the circuit corrections to obtain them are selected by a piano-key switch. Appropriate compensation is applied automatically to the picture contrast as each key is depressed. A full description of the receiver appeared in the issue for the second half of March, 1957, (No. 6) of *Funk-Technik*.

**High-Power Microwave Frequency Doubling** in ferrites is reported by J. L. Melchor *et al.* in *Proc. I.R.E.* for May 1957. The frequency doubling arises from the generation of a double frequency component of magnetization along the direction of the d.c. magnetizing field. The efficiency depends markedly and in a complicated manner on the ferrite geometry. By careful attention to this point a conversion loss of only 6 dB has been achieved for doubling from 9 to 18 Mc/s. Peak and mean power levels can be as high as roughly 32 kW and 20 watts (at 9 Mc/s) respectively.

**Coaxial-Line Monitor Diodes** for the S, X and Q microwave bands are available from Elliott's. These consist of a length of evacuated coaxial line terminated in a dissipative load (iron-loaded resin). When an electromagnetic wave is propagated along the line the potential difference produced by the r.f. energy between the inner cathode and outer anode causes

electrons to flow between them. Owing to the short response time (less than 0.01 μsec), r.f. pulse envelopes can be directly viewed on a c.r.o.; the high output (of the order of 50 volts) being also useful for this purpose. Mixing and demodulation are, of course, also possible. High maximum mean and peak power inputs of at least 10 watts and 50 kW respectively can be accepted. Reflection coefficients of less than 0.09 over the band can be obtained in the tunable holders provided.

**Magnetic-Core Delay Cable**, produced by the Columbia Technical Corporation of New York, contains, inside the inductive winding, a continuous, flexible, low-loss magnetic core which serves to increase the impedance and the unit delay of the line. This kind of delay element is,

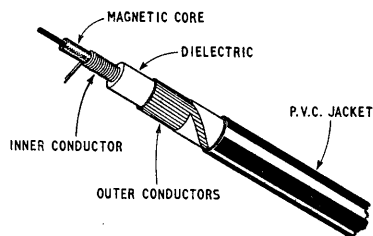

of course, a distributed-parameter type, and does not have the same sort of cut-off frequency as lumped-parameter lines. Rather the attenuation increases gradually with increasing frequency. Cables are available with delays ranging from 0.08 to 1.0 microsecond per foot and with impedances between 1,500 Ω and 3,900 Ω. They are intended mainly for pulse work in a frequency spectrum up to 30 Mc/s and have bandwidths ranging from 6 to 15 Mc/s. Any delay can be obtained by cutting off the appropriate length of cable, and the makers will supply calibrated lengths complete with terminations.

**R.F. Power Transistor**, capable of providing an output of 5 watts at 10 Mc/s either as an oscillator or an amplifier, has been developed at Bell Telephone Laboratories. Normally, of course, it is difficult to make power transistors work at even high audio frequencies because of their necessarily large dimensions. The Bell device, however, which is made from silicon, achieves the high frequency performance by using the diffusion method of forming, together with a p-n-i-p type of structure in which a "neutral" layer of silicon separates the collector from the other elements. Alpha cut-off frequency is about 100 Mc/s and some laboratory samples have apparently provided as much as 1 watt output in oscillation at this frequency. Another silicon power transistor of high performance has now been put into commercial

production by Texas Instruments in the U.S.A. This is the 2N389, with a power dissipation of 37.5 watts at 25°C and 15 watts at 100°C, and it is made by a diffusion process similar to that of the Bell Laboratories. It is intended for use in power circuits which have to operate at high temperatures.

**Transistors in Parallel** for obtaining greater power output from pulse amplifiers are used in a technique described in D.S.I.R. unpublished report PB111665 by J. F. Spades and A. W. Carlson. Parallel operation of the transistor regenerative pulse amplifier is achieved by means of common-base and common-emitter connections, but with each emitter returned through a separate path.

**Microwave Pulse Powers** can be measured from the perturbation of electron beams in a new technique described by H. Thomas in *Proc. I.R.E.* for February 1957. The beam is accelerated transversely through an evacuated section of waveguide carrying power in the TE<sub>10</sub> mode. To a first approximation, the electrons gain energy in one half cycle of the r.f. (when they are in phase with the r.f.), and lose it in the next (when they are out of phase). Thus, if the transit time is an odd number of half cycles, there will be a net gain or loss in the odd half cycle. The accelerating potential is adjusted so that the transit time is such that there is a maximum net gain. This gain is measured by a d.c. cut-off potential. It can be theoretically related to the Poynting vector of power flow. It is necessary to correct for the perturbations in the r.f. field produced by the holes in the waveguide through which the beam passes. This also can be done theoretically. Corrections due to standing waves in the guide can be made either from measurements of the phase and amplitude of these waves, or by using three separated beams. The thermal distribution of the electron's energy produces an uncertainty in the true current cut-off point which can lead to serious errors at low powers. However, by subtracting the apparent cut-off voltage without power flow from that with power flow, this uncertainty is eliminated. The directness of this method is of particular advantage in the measurement of peak pulse powers where the errors are normally about 30% or more. The fact that the power flow is not disturbed by the measurement may also be useful.

*Unpublished Reports mentioned above come from various sources but can be obtained from the Technical Information and Documents Unit of the Department of Scientific and Industrial Research, 15, Regent Street, London, S.W.1.*

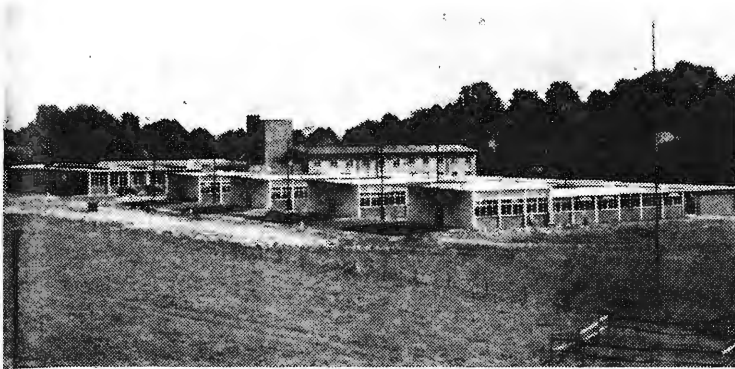

Radio Research Station's new building at Ditton Park, showing the four laboratory units and the administration block in the background.

## New Building for Radio Research Station

IT is perhaps appropriate that the formal opening of the new building at Ditton Park for the Radio Research Station of the D.S.I.R. should take place on the eve of the International Geophysical Year, during which over 1,000 research stations throughout the world will be participating, with the Radio Research Station taking a leading part. The opening ceremony was performed by Sir Edward Appleton, F.R.S.

The new building has accommodation for a staff of 300 and much of the work hitherto carried out in wooden hutments scattered throughout the park, and at the N.P.L., will now be concentrated under one roof. The building consists of a central two-storey administration block with two single-storey wings, one containing laboratories and the other workshops and stores. The laboratories jut out into the field area of the park and have easy access for aerial lead-ins from the many diverse kinds of aerials on which much of the work at the station depends.

Radio wave propagation has always been one of the principal subjects for study at the station and a new development in this field is the utilization of back-scatter for determining skip distances on the short waves. Back scatter results where r.f. waves strike the ground after refraction in the ionosphere and some travel back to the transmitter over the same path as the waves that originated the echoes. Radar technique is used to plot, on a p.p.i. display, echoes from one- two- and sometimes three-hop transmission paths.

Study of the ionosphere has enabled D.S.I.R. to issue long-term forecasts, enabling all users of radio channels to plan their communications some six months in advance. Investigation into the causes of errors in radio direction finding at h.f., v.h.f. and u.h.f. occupies much of the time of the station.

Among the activities at the new laboratories is the study of the properties of ferrites and of semi-conductors.

Interior of one of the laboratories in the new Radio Research Station's Building.

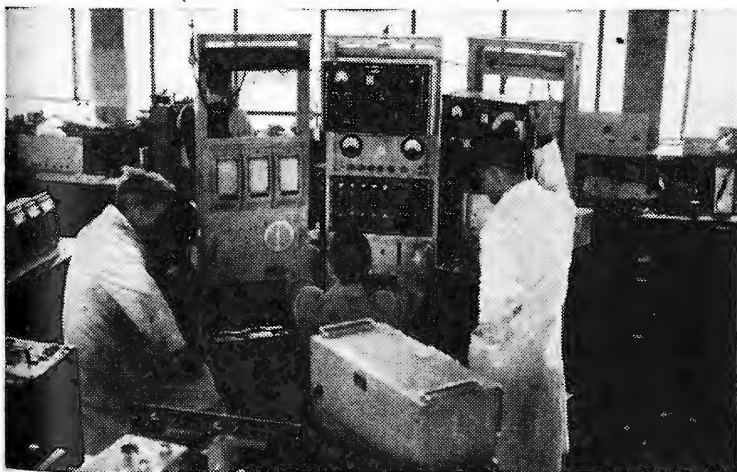

new



DYNAMIC

MICROPHONE

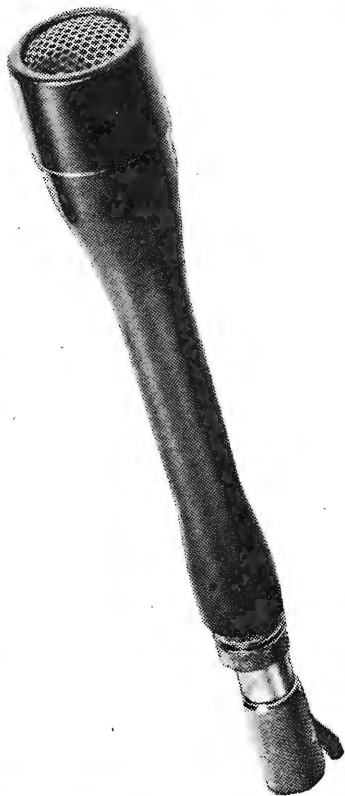

THE MICROPHONE ILLUSTRATED is our new type G7850, a dynamic microphone of outstanding contemporary design. It is finished in bronze black, carries a ring-locking plug connector and is suitable for hand and stand use. Owing to its exceptional top response characteristic, it gives particularly good reproduction of speech and this, allied to its distinguished looks, will make it a welcome and handsome addition to our range of Sound Reproducing Equipment. (Dimensions: Head diam. 1½ in.; Overall length 8¼ in.)

Price: 15 gns.

Please write for full details of our complete range of Sound Reproducing Equipment.

a product of

TRIX ELECTRICAL COMPANY LTD.

1-5 Maple Place, Tottenham Court Road,  
London W. 1

Tel: MUSEum 5817 Grams: Trixadio Wesdo London



# RANDOM RADIATIONS

By "DIALLIST"

## Sound Sense About Aerials

THERE'S good sound sense in the recommendations on TV aerial and feeder installation recently issued by the R.E.C.M.F. From my window, for instance, I can see a horizontal array so erected that it overhangs a chimney pot and is less than a foot above it. One hates to think of the devastation when the sweep comes to do his stuff! Very rightly, this sort of thing is frowned on, as is the all-too-common practice of letting feeders straggle over roofs without tile clips to anchor them. As I watch some of these blowing about over slates and tiles I can't help wondering that breakages of feeder "inners" isn't a whole lot commoner than it is. Another useful point made is that feeders must not be taken over the outer edge of gutterspouts unless stand-off brackets are used. I wonder whether some of the makers of TV aerials could re-institute short courses for erectors. It would be a jolly good thing if they did, for careless, slovenly erection is often responsible for breakdowns for which the aerial makers are quite unjustly blamed.

## FM/DX

THE ranges at which reception from the B.B.C.'s f.m. stations has been reported are quite uncanny. Writing from Sidcot Heaton, near Bolton in Lancashire, a reader tells me that before the Holme Moss service started he had no trouble about getting Wrotham, though it is well over 200 miles from him. It was receivable with an improvised single dipole (lengths of brass wire fixed to a thin board with paper clips!). The signal was so strong at night-time that it came in loud and clear in no matter what direction the dipole was pointed—and even if it was turned from horizontal to vertical. Wrotham seems, for some reason which eludes me, to be pushing out the most far flung of the Band II transmissions. I've had reports of it from many parts of the country. In my East Anglian home town we normally get our v.h.f. programmes from Norwich. But these are the Midland programmes in the Home Service. If there's an item from London that we want to hear there's not the least

difficulty about doing so if you have an indoor aerial and can reorient it. Our friend has separate outdoor aerials for Norwich and Wrotham and can take his choice.

## Timeo Danaos

"I'VE my doubts about those Greeks though they come with gifts in their hands," as the Trojans had good cause to feel when they were offered the fatal wooden horse. Now it's the Irish Republic which is scratching its head over the offers made to it to put up a television transmitter free of charge in return for the sole use of it for some hours every day. As those hours would, one imagines, be used for advertising, it must be plain that the object of the would-be-benefactors can hardly be to serve only Southern Ireland with its rather small population. One feels that they'd like to build a station with a very high e.r.p. and capable of reaching Northern Ireland as well as considerable portions of this country. Mutual interference between TV transmitters has already become quite a big problem. The Irish station, if built, would presumably have to occupy a channel on Band I or Band III and those available are already pretty well booked up. It's quite understandable that such offers must be very tempting to a country which is

anxious to have a television service, but whose government has not the money to build the transmitter and run the programmes. If, though, any such offer is accepted, I hope there will be very strict provisions that no interference with other stations shall be caused.

## Matters of E.H.T.

IT has often puzzled me that it's almost (if not quite) universal practice to use miniature types for that hard-worked valve, the e.h.t. rectifier. In some cases it may be necessary for space-saving reasons; but there certainly are receivers with heaps of room for a full-sized valve, yet fitted with tiny e.h.t. rectifiers. These little valves are apt to break down more quickly than bigger types would. I know, in fact, of one case in which e.h.t. rectifiers seldom much outlasted their three months' guarantee until an expert friend installed one of larger size. Since then there's been no trouble. Another point which calls for attention is the regulation in some e.h.t. circuits. It can be very poor. You adjust, for example, height, width and focus on Test-card C and get them just to your liking. Now, the test-card contains a good deal more white than the average TV picture and the drain on the source of the e.h.t. can cause



## "WIRELESS WORLD" PUBLICATIONS

	Net Price	By Post
ABACS OR NOMOGRAMS: A. Giet. Translated from the French by H. D. Phippen and J. W. Head ... ..	35/-	35/10
TELEVISION RECEIVING EQUIPMENT. W. T. Cocking, M.I.E.E. 4th Edition ... ..	30/-	31/6
FOUNDATIONS OF WIRELESS. M. G. Scroggie, B.Sc., M.I.E.E. 6th Edition ... ..	12/6	13/6
WIRELESS SERVICING MANUAL. W. T. Cocking, M.I.E.E. 9th Edition ... ..	17/6	18/6
SECOND THOUGHTS ON RADIO THEORY. "Cathode Ray" of <i>Wireless World</i> ... ..	25/-	26/2
RADIO LABORATORY HANDBOOK. M. G. Scroggie, B.Sc., M.I.E.E. 6th Edition ... ..	25/-	26/6
ELECTRONIC COMPUTERS: Principles and Applications Edited by T. E. Ivall ... ..	25/-	25/9
THE OSCILLOSCOPE AT WORK. A. Haas and R. W. Hallows, M.A.(Cantab.), M.I.E.E. ... ..	15/-	15/10
BASIC MATHEMATICS FOR RADIO AND ELECTRONICS. F. M. Colebrook, B.Sc., D.I.C., A.C.G.I. Revised and enlarged by J. W. Head, M.A.(Cantab.). 3rd Edition ... ..	17/6	18/4

A complete list of books is available on application

Obtainable from all leading booksellers or from

ILIFFE & SONS LTD., Dorset House, Stamford Street, London, S.E.1

a voltage drop if the regulation is poor and increase the size of the image. Hence the test-card on which you've so carefully adjusted height and width is actually oversize on the screen and when an ordinary picture comes on you may find it adorned with unwelcome dark borders.

### The Two-in-one Valve

THE use of "compound" valves, such as double-triodes, triode-pentodes, diode-triodes and the like, has become so much standard practice nowadays that you find them in almost every kind of electronic apparatus except the very simplest affairs, or those using transistors throughout. They have many advantages, but those who benefit most largely from these are probably the manufacturers of such apparatus, to whom they mean smaller costs, reduced space requirements and things of that sort. But I'm not so sure that their user benefits to the same extent, particularly in the case of domestic equipment. Thanks to them this may be less bulky than it otherwise would be and the purchase price isn't so high, but when it comes to replacements he feels the draught. If one part of a double valve gives out, the whole thing becomes useless and must be renewed. And that costs more—sometimes a great deal more—than the replacement of the faulty one would come to, if they were two separate valves.

### Are You Earthed?

IT doesn't always pay to take earth connections for granted. I once buried a large biscuit tin with the idea of using it as a first-rate earth for a wireless set. Some months later I dug it up to see how it was getting on and found the whole thing destroyed by the action of acid soil. Not long ago a friend found his set "earthed" in a different way. He was using an indoor aerial in an upstairs room and had taken his earth wire through the floor to an ascending water main in a large cupboard below. It occurred to him one day to see that the connection to the pipe was as it should be: so down he went to have a look at it. He got a bit of a surprise when he found the wire cut and the two ends neatly rolled up. What had happened was that some weeks before the painters had been at work and that the one who was doing the cupboard found that the wire was in his way and took what seemed to him the best way out of the difficulty.

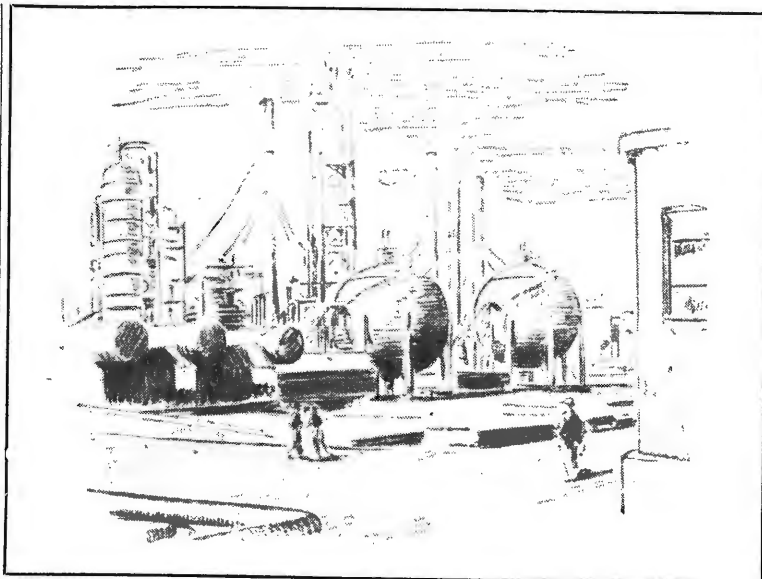

## Electronic components FOR ALL INDUSTRIES

(FUEL-OIL AND SPIRIT)

Used by the principal Oil-producing and Refining Companies in all parts of the world, BULGIN Electronic Components are helping to overcome problems of control, as in all the Scientific and Industrial fields, giving faithful and reliable service. The Bulgin research department and manufacturing units, with their unique skill and experience, build good electronic components on which you can depend.

Over 10,000 different components are available.

★ For full details of Bulgin Components send for fully illustrated Catalogue 197/WW (free to trade letter-heading or order).

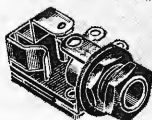
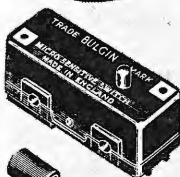
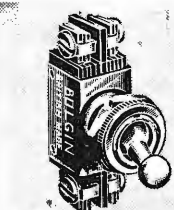

THE HOUSE OF  
**BULGIN**

A. F. BULGIN & CO., LTD.



BARKING, ESSEX.

Tel.: R1Ppleway 5588

MANUFACTURERS OF RADIO AND ELECTRONIC COMPONENTS

## Telephilerers' Troubles

JUST lately we have read a lot in the press about telephone tapping and many of us who are not indulging in what the prayer book calls "seditious and privy conspiracy" cannot help feeling uncomfortable when using the phone to fix up a date with our respective blondes.

After all, even though we are not plotting to overthrow Queen and Parliament we do perhaps say some things to our blondes which sound unconvincing and even a little foolish when set down in cold print. Few of us can rise to the heights of Homer when we try to express our feelings over the phone, and even fewer of us attain to the simple dignity of Barkis when he sent his famous three-word proposal of marriage to Peggotty. Perhaps it is well we do not, for I feel sure that the stolid policeman licking his pencil at the phone-tapping table might easily read something sinister into such a cryptic phrase as "Barkis is Willing".

Naturally I have been hard at work trying to work out an electronic speech scrambler on the lines of the one used in the transoceanic radio-telephone. The difficulties that confront me are economic rather than technical. Each subscriber who desired to be immune from telephone tapping would have to have a scrambling and descrambling unit. But the cost of these devices puts them out of court and their absence is apt to put telephilerers into one even if only the divorce court.

The simplest and cheapest form of "scrambler" is the one the Germans used so successfully in the first World War to convey information and instructions to their agents in certain nearby neutral countries. In those far-off days anybody tuning in to Norddeich heard the station transmitting what appeared to be a continuous high note which in reality was a "scrambled" message.

The *modus operandi* was simple. In Berlin messages were recorded in the ordinary way on a wax cylinder of the type used on the old-fashioned cylinder phonograph and also, of course, on a well-known office dictating machine of those days. The record was then put on a special reproducer having a mandrel rotating at high speed. A primitive mike picked up the resultant high-pitched noise which, at the receiving end, was recorded on another high-speed machine. It was then only necessary for the record to be transferred to an ordinary cylinder reproducer and its message read in the ordinary way.

Surely one of your technological tycoons can think of a workable system lying somewhere between the crudities of the Germans' 1918 device and the prohibitively expensive transoceanic arrangement. At present my blonde and I are both learning Swahili but at any moment it may occur to the authorities to use a tape machine and send the record for translation to one of the big missionary societies, the officials of which might think it their duty to phone the Queen's Proctor at once.

## A Photoarchic Camera

I WAS delighted to see an advertisement in *W.W.'s* sister journal, *Amateur Photographer* (19.6.57) describing a 16mm cine camera in which a photocell is used to operate the iris diaphragm of the camera so that it is always opened to the correct aperture according to the varying conditions of light. Thus the lens is always opened to the correct aperture according to the varying conditions of light available even if a cloud momentarily passes over the sun while shooting.

This is indeed a praiseworthy application of electronics and the reason for my delight is the fact that I first described this type of photoarchic cine camera in this journal

some twenty years ago (20.6.34). It is gratifying to learn that all the big manufacturers of scientific apparatus keep a wary eye on these columns.

In the advertisement it is described as the first cine camera of this type. I have little doubt that the maker of this camera honestly believes this to be the case. After all, we all used to believe that Harvey discovered the circulation of the blood until it was revealed that he was anticipated, several centuries earlier, by an Arabic medical man. But this oriental sage's discovery was forgotten and Harvey made the discovery independently long afterwards. No doubt the camera has been re-invented and its progenitors owe nothing to my former description.

## Is Ernie Radioactive?

I AM very sorry to say that my attempt to use electronic techniques to influence Ernie in my favour, about which I wrote in June, proved a complete flop. At the same time I must take off my hat to the Post Office engineers for their very successful effort to outwit me and others like me. I was unaware of their precautions at the time and thought that my pulse generator had developed a fault.

However, the Editor has solved the mystery by forwarding to me a communication he has received from the Lead Development Association in which it is stated that the whole of Ernie's innards were encased in lead. This would, of course, effectively prevent any outside influence affecting his distributions of largesse.

I am astonished to realize from the wording of the bulletin sent out by the Lead Development Association that its public relations officer obviously does not realize the real reason for Ernie being provided with a lead casing. The P.O. engineering department seems to have informed him that the purpose of the lead casing is to contain the radiations from Ernie's neon tubes and so prevent interference with other parts of his anatomy.

If this be true I cannot for the life of me see why the screening metal had to be of lead and not of some non-plumbeous metal such as we use for screening in our radio sets. Could it be that the P.M.G. has not been as truthful as he might have been and that the real reason for Ernie's lead waistcoat is to shield his audience from harmful radioactivity? That would at least explain the presence of lead. Perhaps the P.M.G.'s technologists will write to the Editor and explain, and maybe the Lead Development Association will join me in this request for enlightenment.



"Barkis is Willing"